

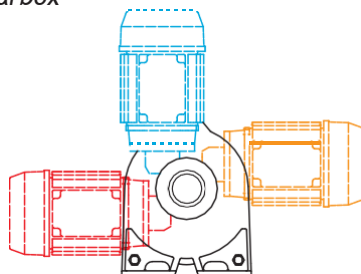

CHANDELIER HOIST FEATURES

- **A choice of four hoists - 100kg, 200kg, 300kg or 470kg lifting capacity**
With different capacities for heights of lift
Larger hoists for heavier duty can also be supplied
- **Operates on standard 240v 13amp supply**
The CH500 is 24v via a supplied transformer
- **Efficient load holding**
Dual braking - independent ratchet brake running in oil and electromagnetic motor brake
- **Lightweight and compact design**
Aluminium die-castings to save weight and the compact design enables installation in small areas
- **Available in different drum lengths**
To provide choice for wire rope length
- **Enclosed drum flange**
Prevents the wire rope becoming trapped between the drum and support casing
- **Smooth running gearbox**
Quiet and efficient spur gearbox

Choice of motor position
CH200 and CH300 motors can be mounted in any of the three positions shown to suit the space available.



TO ESTABLISH WHICH HOIST IS SUITABLE FOR YOUR PROJECT, CALL BHW SALES.
LARGER SIZES OF CHANDELIER HOISTS CAN ALSO BE MADE BY BHW GROUP.

CHANDELIER HOISTS
100-470kg Lifting Capacity
CH100 (100kg), CH200 (200kg)
CH300 (300kg), CH500 (470kg)
240v x 1ph AC

FOR SLOW, SAFE LIFTING AND LOWERING OF LIGHTING FIXTURES



Designed specifically to enable lifting and lowering of ceiling fixtures and fittings, including lighting, for safe and easy access.

Built to the highest standards to ensure reliability and minimum maintenance, these hoists will safely and securely hold ceiling fixtures in place.

Available with spin resistant wire rope.

A double pulley system can enable repairs or maintenance without disconnecting power supply.

Can be calibrated to stop at full ceiling height and preferred lowered position.

HOIST SYSTEMS OPTIONS:

- **Fully pre-wired control box**
For easy electrical installation - complete with contactors and numbered termination blocks
- **'Key only' access control switch**
For additional security and safety
- **Single pulley - for hoist only applications**
When power is not connected, or fixture only requires wire rope
- **Rotational limit switch with upper and lower stop settings**
Calibrated by the installer to suit individual installation
- **Automatic power cable re-winder (if needed)**
Certified as suitable for the application (The kw rating and circuit details of the light fitting should be specified to BHW Group at the time of order)
- **Non rotating wire rope available to correct length**
This is calibrated by BHW Group to allow for winch requirements and the distance from floor to ceiling
- **Protection covers**
To protect the hoist, pulleys or cable rewinders from falling debris or dust

TYPICAL INSTALLATION LAYOUT

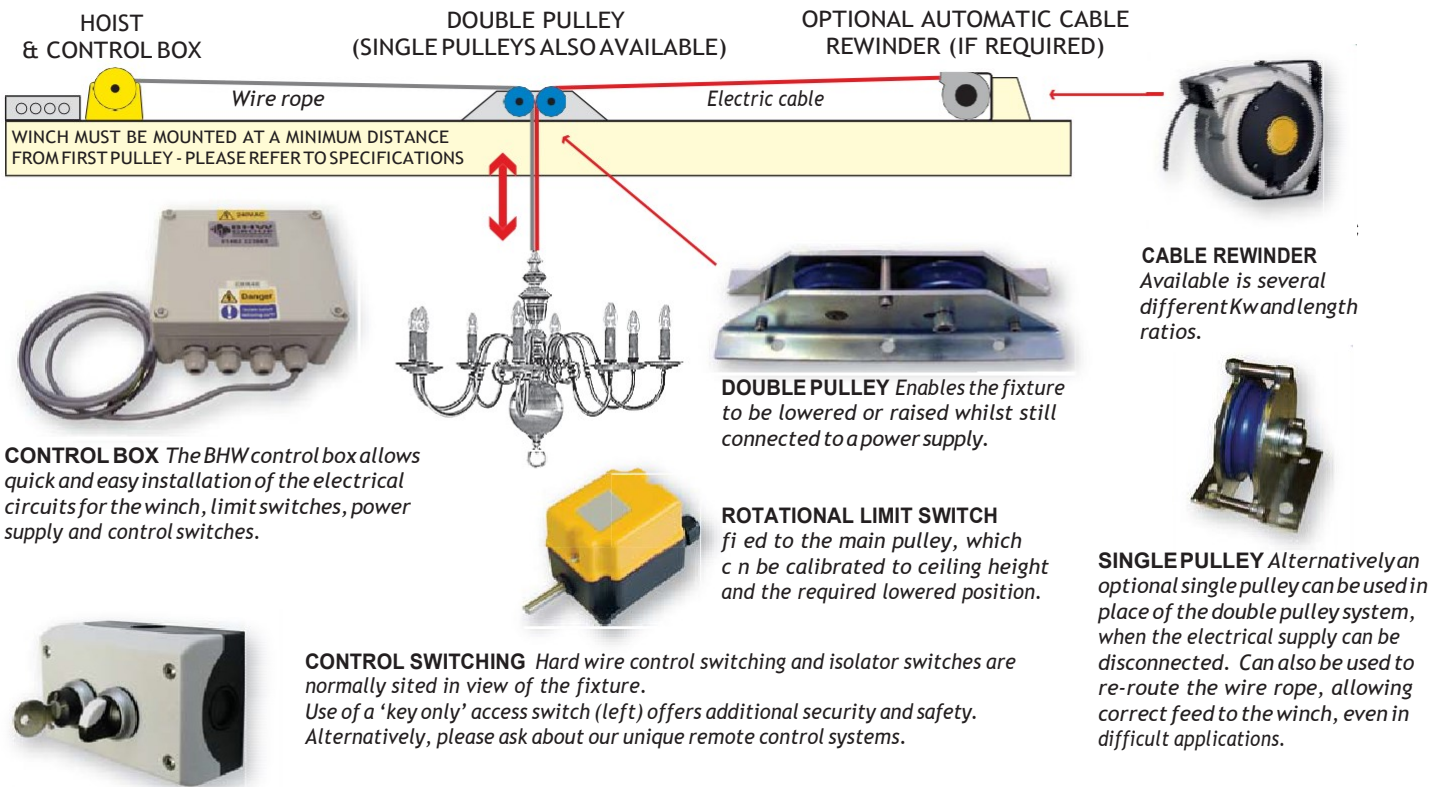

HOIST DIMENSIONS

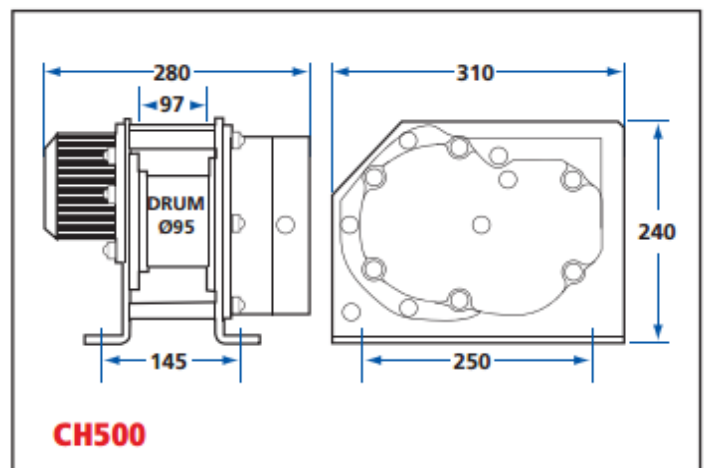
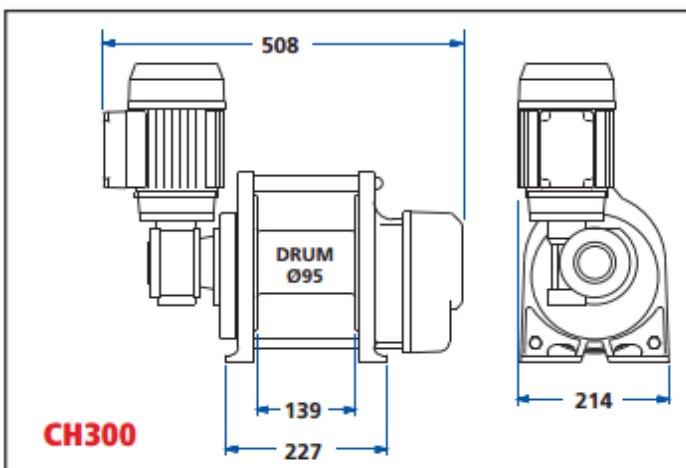
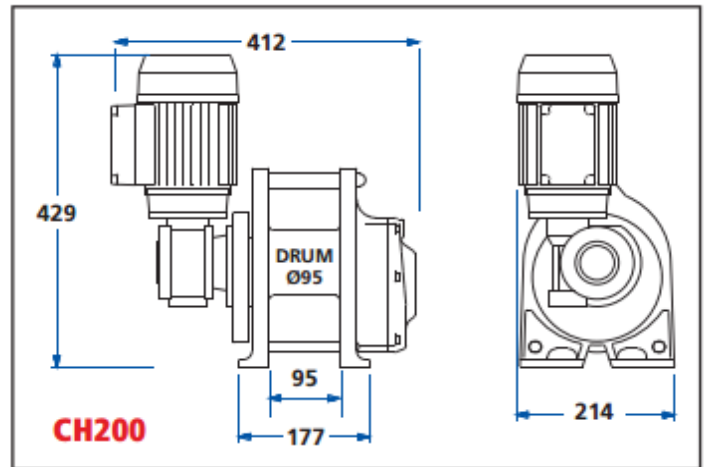
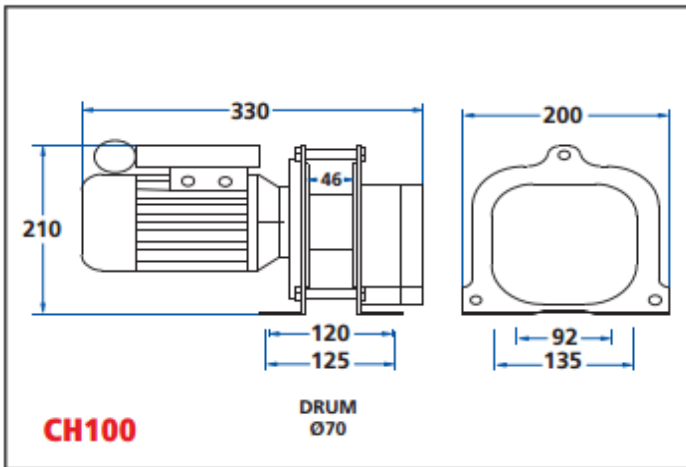

LINE PULL AND LINE SPEED PERFORMANCES

CH100

Rated lifting capacity
100kg on 4th layer

		NUMBER OF ROPE LAYERS ON DRUM							
		1	2	3	4	5	6	7	8
Maximum Rated Line Pull by Layer	kN	1.3	1.2	1.1	0.9	0.9	0.8	0.8	0.7
	kg	135	121	110	100	92	86	80	75
Rope Capacity Cumulative by Layer (4mm Ø Wire Rope)	m	2.5	5.4	8.5	11.9	15.5	19.5	23.8	28.3
Line Speed - m/min		3.5	4.0	4.5	5.1	5.6	6.1	6.6	7.1

CH200

Rated lifting capacity
200kg on 3rd layer

		NUMBER OF ROPE LAYERS ON DRUM							
		1	2	3	4	5	6	7	8
Maximum Rated Line Pull by Layer	kN	2.4	2.2	2.0	1.8	1.7	1.6	1.5	1.4
	kg	243	220	200	185	171	159	149	140
Rope Capacity Cumulative by Layer (5mm Ø Wire Rope)	m	5.8	12.2	19.2	27	35	44	53	63
Line Speed - m/min		3.5	3.9	4.3	4.7	5.0	5.4	5.8	6.1

CH300

Rated lifting capacity
300kg on 3rd layer

		NUMBER OF ROPE LAYERS ON DRUM							
		1	2	3	4	5	6	7	8
Maximum Rated Line Pull by Layer	kN	3.6	3.2	2.9	2.7	2.5	2.3	2.2	2.0
	kg	364	329	300	277	256	238	223	210
Rope Capacity Cumulative by Layer (5mm Ø Wire Rope)	m	8.8	18.5	29.1	40.6	53	66.5	81	96
Line Speed - m/min		2.4	2.6	2.9	3.1	3.4	3.6	3.9	4.1

CH500

Rated lifting capacity
470kg on 3rd layer

		NUMBER OF ROPE LAYERS ON DRUM				
		1	2	3	4	5
Maximum Rated Line Pull by Layer	kN	5.7	5.1	4.6	4.1	3.8
	kg	585	521	470	427	391
Rope Capacity Cumulative by Layer (6mm Ø Wire Rope)	m	4.8	10.2	16.2	22.8	30.1
Line Speed - m/min		2.3	2.6	2.9	3.1	3.4

Cumulative rope capacity denotes total length of rope in metres on the drum according to how many layers.

An assessment of rope length needed for lifting, plus the length required permanently off of the drum is needed to calculate rope lengths for individual applications.

Data shown is approximate and intended as a guide only.

CH100

CH200

CH300

CH500

	CH100	CH200	CH300	CH500
Lifting Capacity (on 3rd layer):	110kg (1.1kN)	200kg (1.96kN)	300kg (2.94kN)	470kg (4.6kN)
Voltage:	240v x 1ph			240v x 1ph from 24v via transformer
Motor type:	Induction motor			Reversible Permanent Magnet Motor
Outputs	Kilowatts: Amperes:	0.18kw 1.6amp	0.37kw 3.6amp	0.37kw 3.6amp
Braking:	Dual mechanical and electromagnetic motor brake			Mechanical Ratchet Brake
Duty Cycle:	All Chandelier Hoists have a duty cycle of 25%, with a maximum of 60 starts per hour			
Weight - hoist only:	9kg	30kg	40kg	34kg
Drum	Diameter: Length: Flange Ø:	70mm 46mm 158mm	95mm 97mm 190mm	95mm 147mm 190mm
Wire rope	Diameter: Construction:	4mm	5mm	5mm
		19 x 7 spin resistant rope, 1960 ² MBL 16.08kN (1640kg) Minimum factor of safety 5:1		
Rope to mean drum ratio:	18:1	20:1	20:1	15:1
Minimum recommended distance of hoist from pulley at ceiling aperture:	500mm	1100mm	1650mm	1165mm

Before installing any hoist system, it is important to work out what possible stress may be put onto the adjacent ceiling joists. A suitable support must be fitted across the joists to spread the load. If in doubt, consult a builder or structural engineer.

NOTES

Please ensure that the fixing point for these hoists are capable of supporting the loads required.

These hoists must not be used for the movement of personnel and 7 wraps of wire rope must be maintained on the drum.

Data shown is approximate and intended as a guide only.

WARRANTY

Each new hoist is guaranteed against defects in workmanship and material defects for a period of twelve months from date of purchase.

Wire ropes are not included under warranty.