

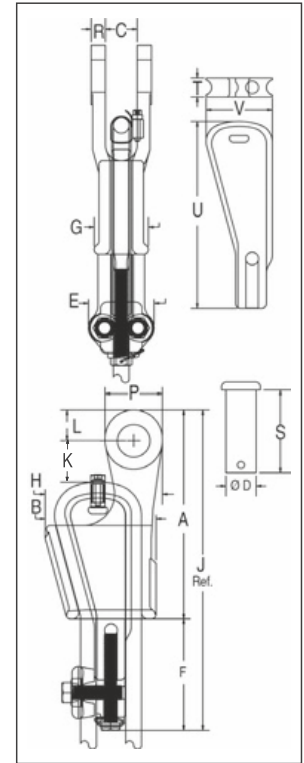

**S-423T**

Wedge sockets meet the performance requirements of Federal Specification RR-S-550F, Type C, except those provisions required of the contractor. For additional information, see page 474 of General Catalog.

- The 423T wedge socket terminations have a minimum efficiency rating on most high performance, high strength, compacted strand, rotation resistant wire ropes of 80% based on the catalog breaking strength of the various ropes.\*\*
- Design eliminates the difficulty of properly seating the wedge with high performance wire rope into a wedge socket termination.
- Proper application of the Super TERMINATOR eliminates the "first load" requirement of conventional wedge socket terminations.
- S-423TW Wedge Kit can be retrofitted onto existing Crosby S-421 TERMINATOR wedge sockets.
- Wedge and accessories provided with a zinc finish
- Meets the performance requirements of EN13411-6.
- Meets or exceeds all requirements of ASME B30.26 including identification, ductility, design factor, proof load and temperature requirements. Importantly, these sockets meet other critical performance requirements including fatigue life, impact properties and material traceability, not addressed by ASME B30.26.
- US Patent 6,898,827.
- Basket is cast steel and individually magnetic particle inspected.
- Pin diameter and jaw opening allows wedge and socket to be used in conjunction with closed swage and spelter sockets.
- Secures the tail or "dead end" of the wire rope to the wedge, thus eliminates loss or "punch out" of the wedge.
- Eliminates the need for an extra piece of rope, and is easily installed.
- The TERMINATOR® wedge eliminates the potential breaking off of the tail due to fatigue.
- The tail, which is secured by the base of the clip and the tension device, is left undeformed.
- **Available with Bolt, Nut, and Cotter Pin.**
- Available with API-2C certification upon request.



Scan this QR code with your smart device to view our Super Terminator video.



**\*\* Due to the unique construction of various ropes, Crosby cannot make a broad general statement that all current and future design of ropes, when properly assembled with the Super TERMINATOR, will achieve a minimum 80% termination efficiency. Contact wire rope manufacturer or Crosby engineering (918-834-4611) to determine efficiency rating for a specific rop**

**SEE APPLICATION AND WARNING INFORMATION**  
 Page 59  
 Para Español: www.thecrosbygroup.com

**S-423T WEDGE SOCKETS** Assembly includes Socket, Wedge, Pin, Wire Rope Clip, Tensioner, Bolts and Secondary Retention Wire.

Wire Rope Dia.		S-423T Assembly with Round Pin and Cotter Pin			S-423TB Assembly with Bolt, Nut and Cotter Pin			S-423TW Wedge Kit		
		S-423T Stock No.	S-423T Weight Each		S-423TB Stock No.	S-423TB Weight Each		S-423TW Stock No.	S423TW Weight Each	
(in)	(mm)		(lb)	(kg)		(lb)	(kg)		(lb)	(kg)
5/8	14- 16	1035123	12.7	5.8	1035218	13.1	5.9	1034018	5.2	2.4
3/4	18-19	1035132	19.4	8.8	1035227	19.1	8.7	1034027	7.2	3.3
7/8	20-22	1035141	28.8	13.1	1035236	27.8	12.6	1034036	10.3	4.7
1	24-26	1035150	39.2	17.8	1035245	37.3	16.9	1034045	11.9	5.4
1-1/8	28	1035169	57.1	25.9	1035254	57.9	25.9	1034054	19.9	9.0
1-1/4	30-32	1035178	88.6	40.2	1035272	88.1	39.9	1034063	33.8	15.3

\*\*Kit contains Wedge, Wire Rope Clip and Bolts, Tensioner Bolt and Secondary Retention Wire.

Wire Rope Dia.		S-423T Stock No.	Dimensions (mm)																
(mm)	(in)		A	B	C	D	E	F	G	H	J*	K	L	P	R	S	T	U	V
14-16	5/8	1035123	210	114	31.8	30.2	76.2	103	54.1	117	313	28.0	31.0	57.2	14.2	82.6	19.1	175	66.0
18-19	3/4	1035132	251	132	38.1	35.1	82.6	122	62.0	136	373	38.0	35.6	66.5	16.8	92.2	22.4	194	76.7
20-22	7/8	1035141	286	149	44.5	41.4	96.8	146	68.3	156	431	40.5	42.4	79.5	19.1	109	25.4	241	88.1
24-26	1	1035150	325	167	50.8	50.8	96.8	146	74.7	179	471	36.5	51.1	95.3	22.4	119	28.7	264	97.0
28	1-1/8	1035169	365	176	57.2	57.2	102	174	85.9	198	539	28.5	57.4	108	25.4	138	31.8	300	107
30-32	1-1/4	1035178	415	219	66.5	63.5	114	197	90.7	238	612	38.0	59.4	114	26.9	168	35.1	352	148

\* Nominal NOTE: For intermediate wire rope sizes, use next larger size socket. The S-423T Super TERMINATOR wedge is designed to be assembled only into the Crosby S-421T TERMINATOR socket body. IMPORTANT: The S-423TW for sizes 14mm through 28mm will fit respective size standard Crosby S-421 basket. The 30-32mm S-423TW will only fit the Crosby S-421 30-32mm basket marked with " TERMINATOR".