

## FEATURES

- SWL 300 kg capacity
- Adjustable span from 900 mm to 2 000 mm
- 2 heights possible (2 jib extensions provided)
- Crane in 3 elements / very quick installation
- Ultra Lightweight - set = 24 KG
- Davit carry bag provided
- Bearing mounted 360 degree pivot
- Powder coating on anodised aluminium
- 2 stainless steel shackles
- Maximum moment = 725 DaN.m.

## 300 kg Portable Lifting Davit

### BENEFITS

Removable, efficient and safe lifting solution, the CMU 300 Portable Lifting Davit improves the responsiveness of your teams.

Its aluminium structure guarantees optimal portability and facilitates interventions on hard-to-reach sites. A single man can take it to site, assemble and be ready to lift in minutes!

8 span-height pairs as standard. Ideal for lifting loads in sewage treatment plants, and generally anywhere where a standard lifting davit cannot be used. Choice of bases available - Cast-in, surface and wall mounted sockets

## 300 kg Portable Lifting Davit

### NEED A QUOTE?

If you would like a quote, please fill out this request form.~  
Complete, save and email to sales@dale-lifting.co.uk

Name	
Company	
Address	
Telephone No.	
Email address	
Notes	
Delivery address if different	

CMU300 Portable Davit in a bag	
Enter quantity required	

1000 mm Post extension to clear handrails	
Enter quantity required	

### OPTIONAL POST EXTENSION

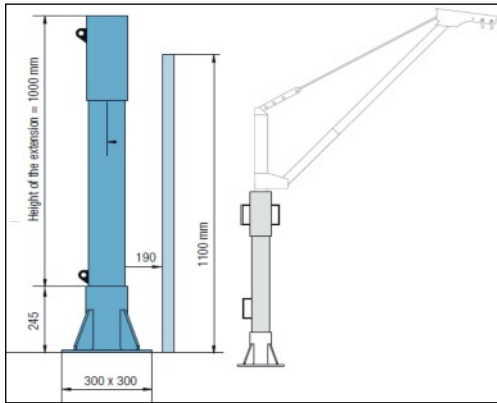

**DALE**  
Lifting and Handling Specialists  
2 Kelbrook Road  
Manchester M11 2QA  
Telephone 0161 223 1990  
Email sales@dale-lifting.co.uk  
Website www.dlhonline.co.uk

### CONFIGURATIONS

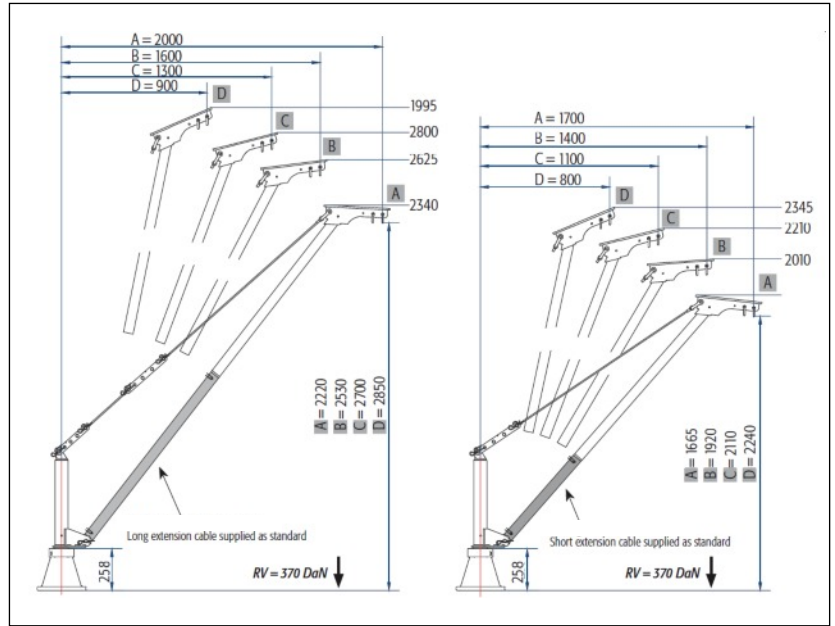

Base installation is the purchaser's responsibility, we recommend consulting a structural engineer or other qualified professional.

### BASE SOCKETS

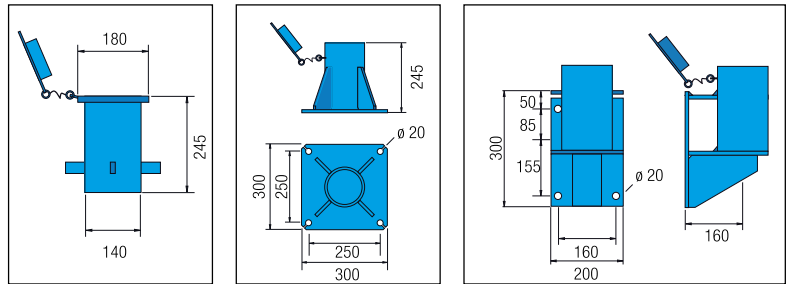

Cast-in Socket Base	Quantity	Surface Mounted Base	Quantity	Wall Mounted Base	Quantity
Galvanised (16 kg)		Galvanised (18 kg)		Galvanised (18 kg)	
Stainless steel (17 kg)		Stainless steel (18 kg)		Stainless steel (18 kg)	



Optional Extras	Finish	Height of lift / length	Quantity
Index lift chain with latch hook	Galvanised	1.0 m	
	Stainless steel	1.0 m	
Pump lifting chain with ring every metre	Galvanised		
	Stainless steel		
Dee shackle (Screw Pin)	Galvanised		
	Stainless steel		
WH Hand chain block	Standard		
	Corrosion resistant		
Yale 360 chain block with rotating guard, allows offset operation	Standard		
	Corrosion resistant		
Delta electric chain hoist 110V	Standard		
Delta electric chain hoist 240V	Standard		
Lodestar electric chain hoist 110V	Standard		
Lodestar electric chain hoist 240V	Standard		