



N.B: Supplied without shackles.

Features and benefits:

- Compact and light - *perfect for stage riggers dealing with limited space*
- Matt black finish - *disappears into stage rigging for zero audience distraction*
- Unique wired and wireless capability via a simple toggle switch - *one load cell for both show-critical events (wired) and more general weighing/monitoring (wireless)*
- Lighter, more compact cabling - *eliminates overly heavy and chunky cabling and gives stage riggers a more portable solution*
- User configurable overload alarms in both wired and wireless modes - *easy to set on site for simple overload protection*
- Constructed from high strength alloy steel - *for best strength to size ratio*
- Accepts standard shackles

StageSafe is a 3t capacity load cell designed exclusively for the entertainment industry.

Offering the accuracy of a load cell (0.3% of applied load) while retaining the best headroom possible (129mm/5") its matt black finish blends in perfectly as part of the stage rigging ensuring there are no distractions from the stage.

StageSafe boasts a unique switching feature allowing it to be used as a wireless or wired load cell.

Wireless mode allows simple, cable-free load monitoring and overload protection across the entire rigging setup and up to 100 StageSafe load cells may be monitored and logged real time on a tablet or laptop using our SW-MWLC software.

Wired mode gives the reassurance and dependability of a cabled load cell meaning it is suitable for show-critical events. The data can then be relayed to a single handheld display or to a PLC or external controller via our range of accessories.

StageSafe shares the industry-leading specifications of other Straightpoint wireless products – 1200 hour battery life, 700 metre / 2300ft wireless range and accuracy you can depend on.

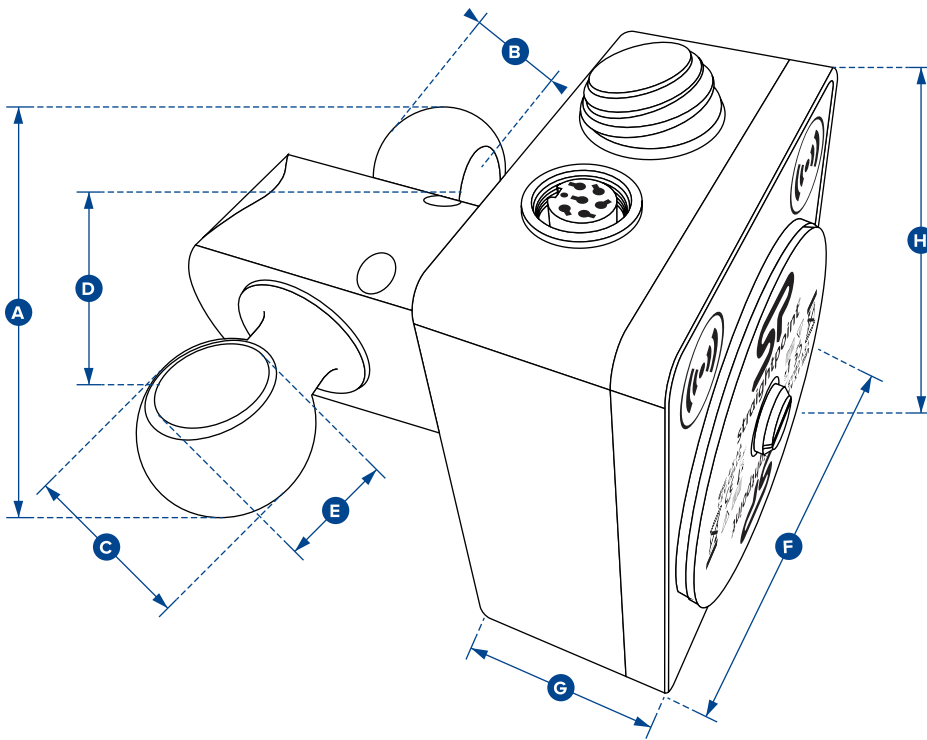

SSDB3T

Capacity	3te 6600lb	
Operation	Wireless	Wired
Operation Selection	Switch	
Resolution	0.001te 2lb	
Weight	1.5kg 3.3lb	
Safety Factor	5:1	
Battery Type	Load cell 4 x AA Alkaline	N/A
Battery Life	Load cell 1200hrs continuous	N/A
Operating Temp	-10 to +50°C / 14 to 122°F	
Accuracy	± 0.3% of applied load	
Wireless Frequency	2.4GHz	N/A
Wireless Range	700 metres / 2300ft	N/A
Data Rate	3Hz (up to 200Hz can be ordered for dynamic load monitoring applications)	N/A
Protection	IP65 (IP67 available as option)	NEMA 4X (NEMA 6 available as option)
Dimension A	129 5.08"	
Dimension B	25 0.98"	
Dimension C	35 1.38"	
Dimension D	88 3.46"	
Dimension ØE	21 0.83"	
Dimension F	102 4.02"	
Dimension G	45 1.77"	
Dimension H	89 3.50"	
Crosby Shackle	G2130-3.25T	

DLHONLINE Division of Dale Group of Companies
 Dale Lifting and Handling Specialists
 2 Kelbrook Road Manchester M11 2QA
 Website www.dlhonline.co.uk Email sales@dale-lifting.co.uk