

DLHONLINE

HOISTING PRODUCTS

Fully interactive 115 page e-brochure
Links to web pages with get-a-quote facility
See section links on page 4.



DLHONLINE
EXPERT ADVICE
EXCELLENT SERVICE



CMCO
COLUMBUS McKINNON

Material Handling - Easily and Safely



TOP DISTRIBUTUTOR

Awarded to Dale & Co. (Manchester) Limited
for outstanding sales, exceptional customer service, brand loyalty
and for upholding Columbus McKinnon values.



www.cmco.eu

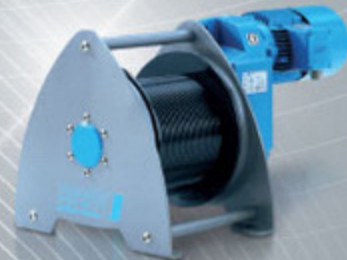

0161 223 1990 **DALE** LIFTING AND HANDLING

DLHONLINE



Hand chain hoists

Electric & Pneumatic chain hoists



Information about corrosion protection and about products for explosion endangered environments can be found

[>>CLICK HERE](#)



Trolleys & Trolley clamps



Manual winches

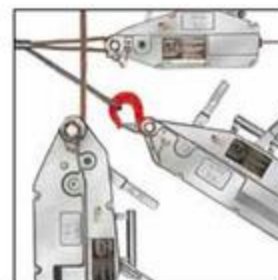

Cable puller & Accessories



Rack & Pinion jacks

 Please note our user instructions at the beginning of each chapter.

DLHONLINE

Hoisting Equipment

Yale and Pfaff-silberblau hoisting equipment products are reliable and proven equipment renowned world-wide for applications in industry, trade and services.

The comprehensive range includes manual and powered hoisting equipment for a safe lifting and handling of loads ranging from 125kg to 20000kg. The products feature a long service life as well as easy and quick maintenance or repair.

Yale and Pfaff-silberblau hoisting equipment products comply with national and international regulations such as the EC Machinery Directive 2006/42/EC and corresponding supplements. In order to meet our high quality standard, the devices are subjected to an overload test in the factory and provided with a test certificate and operating instructions with a declaration of conformity or a manufacturer's declaration.



Electric & Pneumatic winches



Ratchet lever hoists

Table of Contents

Tip! Click  arrows to jump to product section (Not available in PDF)

</userFiles/a/1/0/1/8/5/0/pRWiKyfXM2GC4fA828La4J/JhQWsQns.pdf>

Ratchet lever hoists 

Hand chain hoists 

Corrosion & Explosion protection 

Trolleys & Trolley clamps 

Electric & Pneumatic chain hoists 

Chains & Accessories 

Manual winches 

Cable puller & Accessories 

Electric & Pneumatic winches 

Rack & Pinion jacks

Crane systems

Handy Guides

Power supply 

Electric chain hoists 

Steel rope for manual and powered winches 

Our contact details 

DLHONLINE

This user information presents a general review regarding the operation of hoisting equipment and does not substitute the existing operating instructions for the specific hoist product.

Lifting operations with hoisting equipment may be carried out by competent users (trained in theory and practice) only.

When operated correctly, our hoist products will offer the highest degree of safety in line with long life expectancy and avoid damage to the product and people.

Modification of delivery condition

Design and construction of the hoist may not be altered, e.g. by installation of outside supplied parts, bending, welding, grinding, removal of safety relevant components like locking devices, locking pins, safety latches etc.

Limitations of operation

Loading

Our hoists have been designed for lifting and transporting of loads. Some models (e.g. ratchet lever hoists) may also be used for pulling and lashing purposes, if admitted in the operating instructions. The indicated capacities refer to loading in straight line and must not be exceeded. Lifting media (e.g. lifting chain or rope) must not be slung over edges and must not be used for the attachment of the load.

Temperature

Hoists may normally be operated at ambient temperatures between -10 °C up to +50 °C.

These values are approximate and may deviate from the specific givings of the hoist product. The accurate data are given in the current operating instructions. Special models are available on request for higher or lower temperature ranges.

Attention: At temperatures below 0 °C the brake should be checked for freezing. (Check lifting function prior to starting work and refer to "Inspection prior to initial operation").

Shock loading

The indicated capacities are based on shock-free loading of the hoist. Light bumps as occurred during lifting and lowering as well as transporting of load are admitted. Heavier shock loadings, e.g. falling of the load, are strictly forbidden.

Chemicals

Hoists and attachments may not be operated without hesitation in the area of chemicals or chemical vapours – consult our specialists for advice. Hoists which have been subject to chemicals or vapours must be taken out of service and inspected by us.

Transport of people

Transport of people with hoisting equipment is generally forbidden! Transport of people may only be carried out with specially authorized products (e.g. Yaletrac, Mtrac).

Operation in danger zones

Lifting or transport of loads must be avoided while personnel are in the danger zone.

People are not allowed to pass over or under a suspended load.



Electrical hazards

Load carrying hoist components (e.g. load chain) must not be subject to electric current and must never be used as a ground connection during welding. Further electrical hazards, e.g. with powered hoists, are indicated in the specific operating instructions!

Electric connections may only be performed by authorized persons resp. companies.

DLHONLINE

Application advices

- Hoists must always be in perfect condition and provided with a legible identity plate.
- Prior to starting work, the hoist including load carrying devices, equipment, supporting structure and suspension must be inspected for obvious deficiencies and failures. In addition, the function of the brake and the correct attachment of hoist and load have to be checked by carrying out a short work cycle of lifting/pulling or tensioning and releasing.
- Inspect the load chain for sufficient lubrication and visually check for external defects, deformations, superficial cracks, wear or corrosion marks. A defective chain must be replaced prior to operation of the hoist.



- Units equipped with two chain falls should be inspected for twisted or kinked chains prior to being put into operation. The chains of multiple fall hoists may be twisted if the bottom block was turned over.
- Inspect top and bottom hooks for deformations, damage, cracks, wear or corrosion marks. A safety latch must be available and work effectively.
- Hoists with obvious defects and units which have been subject to overload or other dangerous influences have to be taken out of service and may only be operated after test and repair if so required.
- When selecting the proper product, make sure that the hoist is suitable to accept transportation, suspension, type of lashing devices and lashing points safely and without unintended movement (e.g. slipping).
- Load chains must not be used in kinked or knotted condition.



- The load must always be seated in the saddle of the hook. Never attach the load on the tip of the hook. This applies to top and bottom hooks.
- The operator must ensure that the load is attached in a manner that does not expose himself or other personnel to danger by the hoist, chain(s) or the load.
- During lifting operations the load and suspension hook of the hoist must be perpendicular to the load center to prevent pendle motion of the load.
- The operator may start moving the load only after it has been attached correctly and all personnel are off the danger zone.

- Before lifting make sure that the load can move freely.
- After lifting or tensioning, a load must not be left unattended for a longer period of time.
- Chain stops, slipping clutches etc. are overload protection devices and may not be used as regular load limiters.
- Do not throw the hoist down. Always place it properly on the ground.

Labelling (Example)

UNOplus 1,5 TON

Tragfähigkeit/S.W.L./
Capacité 1500kg

Baujahr/Mfg. Year/
Produit en 20__

Ser.Nr./Ser.no. _____

Lastkette/Load chain/
Chaine 8x24-T(8)

Hubhöhe/Lift/
Levée _____m

SHP: 35daN
STF: 1500daN
EN 12195-3

Yale COLUMBUS MCKINNON
Ind. Products GmbH
Am Lindenberg 31
42549 Velbert/Germany

CE

Rated capacity ————

Grade and dimension of load chain ————

Manufacturer or supplier ————

Year of manufacture ————

Serial or model number ————

Lifting height (not mandatory) ————

DLHONLINE



DLHONLINE

Maintenance and repair

- To ensure safe operation, all hoisting equipment must be subjected to regular inspections according to the maintenance instructions given by the manufacturer.
- Hoists which are due for maintenance (normally once per year, unless adverse working conditions dictate shorter periods) or products with obvious defects may be returned to us for inspection and repair.
- Inspections and tests must be performed by competent persons or specialist workshops that use original spare parts.

Inspections

- According to German laws and standards all hoisting equipment must be subjected to a mandatory inspection at least once a year. The inspection must be performed by a competent person.
- On building sites hoists have to be inspected every time before operation.
- Hoist and supporting components have to be cleaned prior to inspection. The cleaning procedure must not cause chemical damages (e.g. no acid-embrittlement). Do not expose the hoist and supporting components to unallowed temperatures by e.g. flame cleaning avoid concealment of cracks and excessive material loss (sand blasting).
We shall be pleased to consult you in this respect. Please submit your hoists for inspection in clean condition. This will reduce inspection costs considerably.

Criteria for hoist disposal

Hoists must no longer be operated if e.g.:

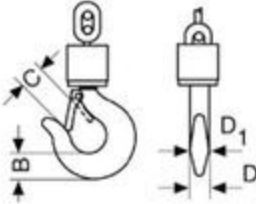
- The identification (identity plate) is missing or illegible.
- Security relevant components like brake, slipping clutch, ratchet pawls etc. do not properly function any longer.
- Housing, control units and suspension of the hoist present obvious deficiencies, i.e.
 - cuts, grooves, cracks
 - excessive corrosion
 - staining due to heat
 - signs of subsequent welding resp. spatters which cannot be easily removed and leave stains.
- Ropes show breakage of wires resp. bruises (criteria for disposal of ropes are given in classification DIN 15020), damages to the rope sleeve and similar failures.
- The load chain presents twisted or distorted links or shows an elongation of 5% of one chain link or a reduction in diameter of more than 10% (average of two measurements (longitudinal and transverse) compared to the nominal diameter).
- The opening (C) of suspension and/or load hooks is stretched by more than 10% compared with the nominal dimension, or if the hook mouth shows a wear of more than 5% of either dimension B or D.
 
- Detrimental impacts by e.g. overloading, shock loading, chemical influences or heat have occurred, the hoist may only be returned to service after careful inspection and repair.

DLHONLINE



Ratchet lever hoist with roller chain model C 85

Capacity 750 - 10000 kg

Ratchet lever hoist with link chain model D 85

Capacity 750 - 10000 kg

Almost unlimited applications in maintenance, mining, construction, steel fabrication, shipbuilding and utility work. Ideal for moving and positioning heavy machines and securing heavy loads, simplifies setting pipes etc. in manholes and trenches.

Features

- Enclosed housing with housing cover, handlever and bottom block made from high tensile white malleable cast iron for overall rugged construction.
- The graphite cast iron load sheave for the link chain has precision machined chain pockets for accurate fit and durability of the load chain.
- The roller chain sprocket is made from heat treated chromium-molybdenum steel with precision machined teeth to ensure smooth chain movement.
- Alloyed steel link chain with zinc-plated resp. yellow chromated finish, in accordance with national and international standards and regulations.

Options

- All models can be equipped with an overload prevention device in the form of a slip clutch which is factory preset to approx. 25% ± 15% overload.
- Free chaining device to quickly attach the load or to pull the chain through the hoist in both directions.
- Hoist with sling chain.

Since 1936 more than 1 million units have been built in Velbert.



Option:
Overload protection for
D95 and C/D85.

Find out more about this product or get a quotation

This ratchet lever hoist is suitable for cargo tie down applications, since it has an automatic screw-and-disc type load brake preventing an unintentional loosening of the load.

DLHONLINE

Technical data model C 85

Model	EAN-No. 4025092*	Capacity kg	Number of chain falls	Chain dimensions d x p Inch	Lift with one full lever turn mm	Handle pull at WLL daN	Weight at standard lift (1.5 m) kg
PULLIFT C 85 750	*050173	750	1	5/8" x 3/8"	115	38	8.7
PULLIFT C 85 1500	*050180	1500	1	1" x 1/2"	45	31	17.0
PULLIFT C 85 3000	*050197	3000	1	1 1/4" x 5/8"	36	40	22.2
PULLIFT C 85 6000	*050203	6000	2	1 1/4" x 5/8"	18	44	38.0
PULLIFT C 85 10000	*050326	10000	3	1 1/4" x 5/8"	12	44	67.0

Dimensions model C 85

Model	PULLIFT C 85 750	PULLIFT C 85 1500	PULLIFT C 85 3000	PULLIFT C 85 6000	PULLIFT C 85 10000
A min., mm	322	389	403	560	785
B, mm	21	27	35	48	61
C, mm	27	30	34	46	54
D, mm	15	20	25	40	40
D1, mm	17	23	25	40	45
E, mm	443	443	570	570	570
F, mm	112	189	197	197	305
G, mm	56	134	142	142	163
H, mm	56	55	55	55	142
J, mm	142	171	179	218	218
K, mm	39	72	76	76	76
L, mm	103	99	103	142	142

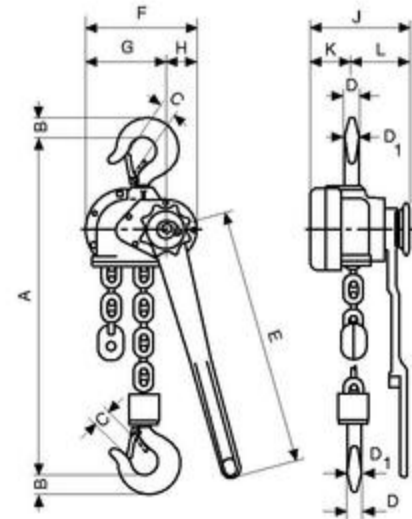

Find out more about this product or get a quotation

Technical data model D 85

Model	EAN-No. 4025092*	Capacity kg	Number of chain falls	Chain dimensions d x p mm	Lift with one full lever turn mm	Handle pull at WLL daN	Weight at standard lift (1.5 m) kg
PULLIFT D 85 750	*050548	750	1	6 x 18,5	111	38	8.2
PULLIFT D 85 1500	*050555	1500	1	9 x 27	45	31	16.3
PULLIFT D 85 3000	*050562	3000	1	11 x 31	33	40	19.6
PULLIFT D 85 6000	*050579	6000	2	11 x 31	17	42	32.9
PULLIFT D 85 10000	*050784	10000	3	11 x 31	11	37	60.0

Dimensions model D 85

Model	PULLIFT D 85 750	PULLIFT D 85 1500	PULLIFT D 85 3000	PULLIFT D 85 6000	PULLIFT D 85 10000
A min., mm	322	389	403	532	805
B, mm	21	27	35	48	61
C, mm	27	30	34	46	54
D, mm	15	20	25	40	40
D1, mm	17	23	25	40	45
E, mm	443	443	570	570	570
F, mm	112	189	197	197	305
G, mm	56	134	142	142	163
H, mm	56	55	55	55	142
J, mm	142	171	179	218	218
K, mm	39	72	76	76	76
L, mm	103	99	103	142	142

Yale hoists and trolleys are not designed for passenger elevation applications and must not be used for this purpose.

DLHONLINE



Ratchet lever hoist with link chain model D95

Capacity 1500 - 3000 kg

The D95 in its cast malleable iron design has taken key technical features from the proven D85 but excels due to low tare weight and an extremely small measurement between suspension and load hooks. A versatile unit for moving, positioning and securing loads.

Features

- Enclosed housing with housing cover, handlever and bottom block made from high tensile malleable cast iron for overall rugged construction.
- The short handlever is fitted with an ergonomic rubber grip.
- It has an automatically acting load pressure brake which works on the self-locking principal. For example, when used to secure loads an unintentional loosening of the brake is prevented when the load vibrates.
- Standard free chaining device to quickly attach the load or to pull the chain through the hoist in both directions.
- Alloyed steel link chain with zinc-plated resp. yellow chromated finish, in accordance with national and international standards and regulations.

Options

- All models can be equipped with an overload prevention device in the form of a slip clutch which is factory preset to approx. 25% ± 15% overload.
- Hoist with sling chain.

DISCONTINUED

- ! This ratchet lever hoist is suitable for cargo tie down applications, since it has an automatic screw-and-disc type load brake preventing an unintentional loosening of the load.



Hoist with sling chain

DLHONLINE

Technical data model D 95

Model	EAN-No. 4025092*	Capacity kg	Number of chain falls	Chain dimensions d x p mm	Lift with one full lever turn mm	Handle pull at WLL daN	Weight at standard lift (1.5 m) kg
PUL-LIFT D95 1500	*050807	1500	1	6.2 x 18.5	35	27	9.9
PUL-LIFT D95 3000	*050821	3000	1	9 x 27.2	38	49	16.5

Dimensions model D 95

Model	PUL-LIFT D95 1500	PUL-LIFT D95 3000
A min., mm	314	376
B, mm	23	30
C, mm	23	25
D, mm	18	22
D1, mm	18	22
E, mm	315	443
F, mm	156	189
G, mm	112	134
H, mm	44	55
J, mm	141	177
K, mm	49,5	72
L, mm	92	105

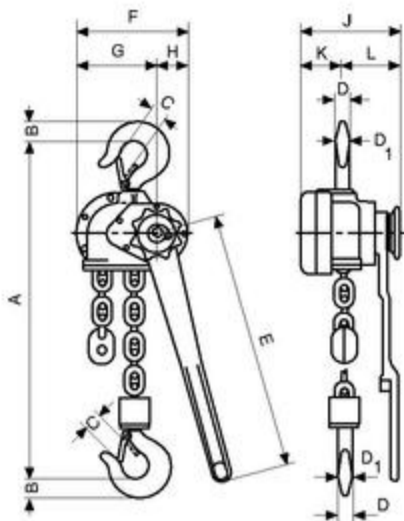

DISCONTINUED

! Yale hoists and trolleys are not designed for passenger elevation applications and must not be used for this purpose.

DLHONLINE

Ratchet lever hoist model AL

Capacity 750 - 3000 kg

Its low tare weight is an advantage. When the hoist has to be frequently carried over longer distances to different assignments. This universal ratchet hoist should not be missing in any service truck.

Features

- The enclosed housing, hand lever and hand wheel are made from high quality aluminium.
- Low effort on hand lever.
- Due to precise needle bearings the hoist can be operated with little effort.
- Standard free chaining device to quickly attach the load or to pull the chain through the hoist in both directions.
- The chain guide is cast into the body to ensure faultless chain movement.
- Alloyed steel link chain with zinc-plated resp. yellow chromated finish, in accordance with national and international standards and regulations.

Option

- Stainless steel load chains.

Yale hoists and trolleys are not designed for passenger elevation applications and must not be used for this purpose.



All ratchet lever hoists with a capacity exceeding 750 kg can be used for load attachment according to EN 12195.



Find out more about this product or get a quotation

Technical data model AL

Model	EAN-No. 4025092*	Capacity kg	Number of chain falls	Chain dimensions d x p mm	Lift with one full lever turn mm	Handle pull at WLL daN	Weight at standard lift (1.5 m) kg
AL 750	*051194	750	1	6.3 x 19.1	30	16	6.4
AL 1000	*051200	1000	1	6.3 x 19.1	30	22	6.6
AL 1500	*051217	1500	1	7.1 x 21.2	16	18	10.0
AL 3000	*051224	3000	1	10 x 30.2	14	28	18.0

Dimensions model AL

Model	AL 750	AL 1000	AL 1500	AL 3000
A min., mm	315	325	380	455
B, mm	20	23	27	36
C, mm	22	23	26	33
D, mm	14	16	20	24
E, mm	300	300	300	400
F, mm	106	109	138	168
G, mm	47	47	60	75
H, mm	59	62	78	93
J, mm	154	154	177	212
K, mm	49	49	74	94
L, mm	105	105	103	118

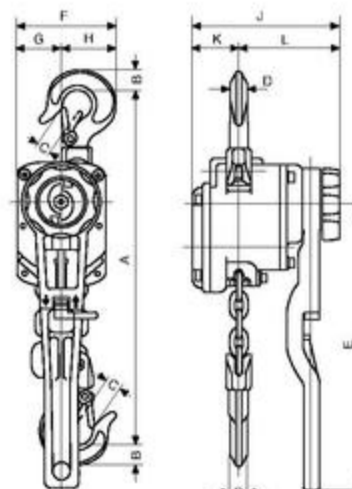

DLHONLINE

Ratchet lever hoist model PT

Capacity 800 - 6300 kg

Ratchet lever hoists model PT features improved techniques and ergonomical styling. The advantages of the predecessor range have been maintained and further optimized.

A good, versatile, all round ratchet lever hoist for demanding conditions.

Features

- The proven stamped steel housing provides extremely low weight without limiting the reliability and sturdiness of the unit.
- The short handle lever is fitted with an ergonomic rubber grip.
- Standard free chaining device to quickly attach the load or to pull the chain through the hoist in both directions.
- Alloyed steel link chain with zinc-plated resp. yellow chromated finish, in accordance with national and international standards and regulations.
- Drop forged suspension and load hooks are made from non-aging, high tensile steel and fitted with robust safety latches.

Options

- All models can be equipped with an overload prevention device in the form of a slip clutch which is factory preset to approx. 25% ± 15% overload.



► Find out more about this product or get a quotation



Option:
Overload prevention device

! All ratchet lever hoists with a capacity exceeding 750 kg can be used for load attachment according to EN 12195.

Technical data model PT

Model	EAN-No. 4025092*	Capacity kg	Number of chain falls	Chain dimensions d x p mm	Lift with one full lever turn mm	Handle pull at WLL daN	Weight at standard lift (1.5 m) kg
PT 800	*076463	800	1	5.6 x 17.1	24	26	5.5
PT 1600	*076470	1600	1	7.1 x 21.2	23	30	9.6
PT 3200	*076487	3200	1	9 x 27.2	16	38	16.0
PT 6300	*076494	6300	2	9 x 27.2	8	39	31.0

Dimensions model PT

Model	PT 800	PT 1600	PT 3200	PT 6300
A min., mm	290	330	430	580
B, mm	21	27	36	53
C, mm	24	31	35	46
D, mm	13	20	24	43
E, mm	235	370	370	370
F, mm	120	138	177	259
G, mm	38	41	53	85
H, mm	82	97	124	174
J, mm	142	163	185	185
K, mm	52	65	83	83
L, mm	90	98	102	102

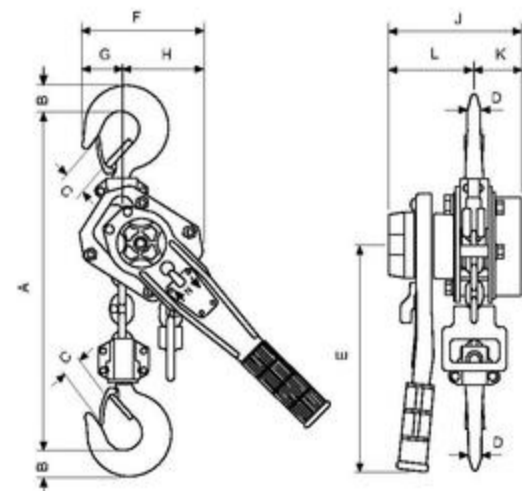

DLHONLINE



Ratchet lever hoist model UNOplus

Capacity 750 - 6000 kg

Further technical development turns the ratchet lever hoist into the successor of our proven UNO model. The versatile tool for lifting, pulling and securing of loads is characterised by its compact design and robust stamped steel construction.

Features

- Due to optimized gearing and improved bearings in the housing cover a minimum effort is required to operate the short hand lever.
- Steel hand wheel as standard.
- Automatic screw-and-disc type load brake with corrosion protected components.
- Standard free chaining device to quickly attach the load or to pull the chain through the hoist in both directions.
- Robust chain guide rollers eliminate fouling and jamming of chain on the load sheave.
- Sturdy bottom block with encapsulated bolt connections
- Alloyed steel link chain with zinc-plated resp. yellow chromated finish, in accordance with national and international standards and regulations.
- Drop forged suspension and load hooks are made from non-aging, high tensile steel and fitted with robust safety latches.

Find out more about this product or get a quotation

All ratchet lever hoists with a capacity exceeding 750 kg can be used for load attachment according to EN 12195.



Available in explosion proof version.

Technical data model UNOplus

Model	EAN-No. 4025092*	Capacity kg	Number of chain falls	Chain dimensions d x p mm	Lift with one full lever turn mm	Handle pull at WLL daN	Weight at standard lift (1.5 m) kg
UNOplus 750	*168342	750	1	6 x 18	20	20	7.2
UNOplus 1500	*168359	1500	1	8 x 24	22	35	12.5
UNOplus 3000	*168366	3000	1	10 x 30	17	40	21.5
UNOplus 6000	*168380	6000	2	10 x 30	9	40	32.0

Dimensions model UNOplus

Model	UNOplus 750	UNOplus 1500	UNOplus 3000	UNOplus 6000
A min., mm	340	410	510	690
B, mm	22	28	36	45
C, mm	26	32	40	44
D, mm	16	21	27	33
E, mm	250	330	380	380
F, mm	150	170	220	220
G, mm	70	80	100	100
H, mm	80	90	120	120
J, mm	150	180	210	210
K, mm	60	80	90	90
L, mm	90	100	120	120

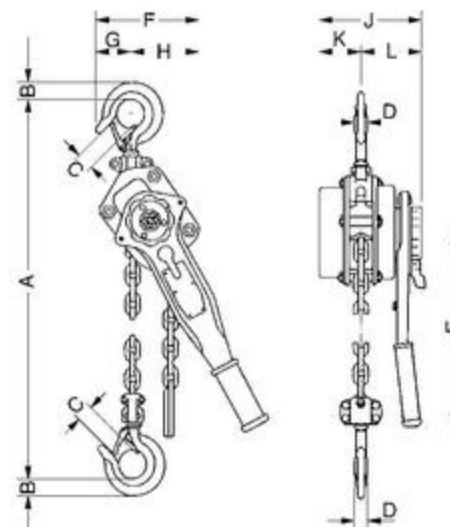

DLHONLINE

Ratchet lever hoist model Yalehandy

Capacity 250 - 500 kg

The extreme low tare weight and the very compact design make the hoist easy to use even in confined working conditions. Due to the multitude of application possibilities e.g. in industry, trade and service this ratchet lever hoist is indispensable.

Features

- The enclosed design protects the internal parts from contamination.
- The short handle lever is fitted with an ergonomic rubber grip.
- All parts of the disc type load brake are manufactured from high quality materials and are corrosion protected.
- Standard free chaining device to quickly attach the load or to pull the chain through the hoist in both directions.
- Alloyed steel link chain with zinc-plated resp. yellow chromated finish, in accordance with national and international standards and regulations.
- Drop forged suspension and load hooks are made from non-aging, high tensile steel and fitted with robust safety latches.



! Yale hoists and trolleys are not designed for passenger elevation applications and must not be used for this purpose.

► Find out more about this product or get a quotation

Technical data model Yalehandy

Model	EAN-No. 4025092*	Capacity kg	Number of chain falls	Chain dimensions d x p mm	Lift with one full lever turn mm	Handle pull at WLL daN	Weight at standard lift (1.5 m) kg
Yalehandy 250	*075039	250	1	4 x 12	80	25	2.2
Yalehandy 500	*077675	500	1	4 x 12	40	25	2.8

Dimensions model Yalehandy

Model	Yalehandy 250	Yalehandy 500
A min., mm	240	282
B, mm	20	17
C, mm	21	24
D, mm	14	12
E, mm	160	160
F, mm	72	104
G, mm	33	38
H, mm	39	66
J, mm	98	116
K, mm	21	36
L, mm	77	80

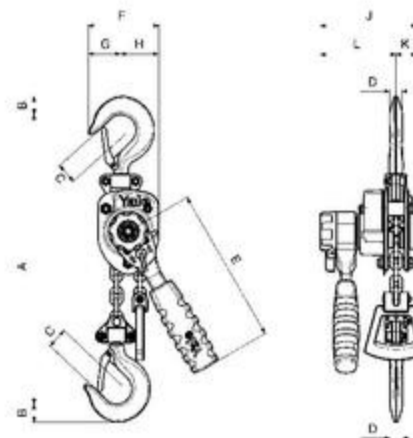

DLHONLINE



*Patented!
Rotating hand
chain guide*

Hand chain hoist model Yalelift 360

Capacity 500 - 20000 kg

Areas of operation as well as operator conditions have been improved far beyond those of a classical hand chain hoist.

Features

- The enclosed robust stamped steel housing protects all internal components even in the toughest conditions.
- The extremely low headroom allows maximum use of the lifting height.
- The revolutionary 360° rotating hand chain guide allows the operator to work from virtually any position, in confined spaces or above the load. The Yalelift can even be operated from the side of the load which also makes it possible to use the hoist for horizontal pulling or tensioning. Due to the additional flexibility, the operator is no longer forced to work in the danger zone near the load.
- The brake system is extremely quiet and guarantees operational safety and improved serviceability due to omission of the vulnerable ratchet pawls. All parts are made of high quality materials, additionally zinc-plated or yellow-chromated to increase corrosion prevention.
- Chain guide and gearbox are almost totally enclosed. Even under the toughest conditions the internal gearbox remains protected.
- The hardened load sheave with four precision machined pockets ensures accurate movement of the load chain.
- The surface protected zinc-plated alloy steel load chains fulfil all requirements of current national and international standards and regulations.
- Drop forged load and suspension hooks that yield under overload instead of breaking, are made of high tensile steel. The hooks are fitted with robust safety latches and rotate 360°.



Available in
explosion proof version.

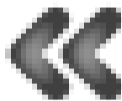

Chain guide



High quality encapsulated ball bearings and sliding bushes for smooth and effortless operation.

Options

- Adjustable overload prevention device.
- Stainless steel load and hand chains.
- Chain container
- Corrosion resistant version
- Explosion proof version

! Easy modification from Yalelift 360 to Yalelift IT is possible.



Find out more about this product or get a quotation

DLHONLINE

Hand chain hoist model Yalelift 360 20t

Capacity 20000 kg

The brake system used in the Yalelift series is also employed in the Yalelift 360 20t, setting standards in terms of operational safety and serviceability. The brake is extremely quiet and wear resistant. In spite of its high capacity, the Yalelift 360 20t features a compact design.

Features

- All components are made of high quality materials, some components are zinc-plated or yellow-chromated for added corrosion protection. This ensures that also heaviest loads are held reliably.
- The enclosed robust stamped steel body resists in the toughest conditions and allows outside operation.
- The hardened load sheave with five precision machined pockets ensures accurate movement of the load chain.
- The low headroom (hook-to-hook dimension 1010 mm) allows maximum use of the lifting height.
- The Yalelift 360 20t is equipped with six chain falls only which results in higher speed and lower weight.

Options

- Adjustable overload prevention device.
- Stainless steel load and hand chains.
- Chain container
- Corrosion resistant version
- Explosion proof version

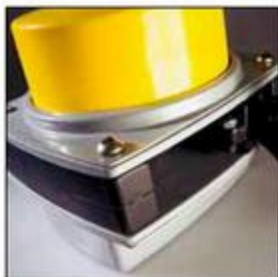
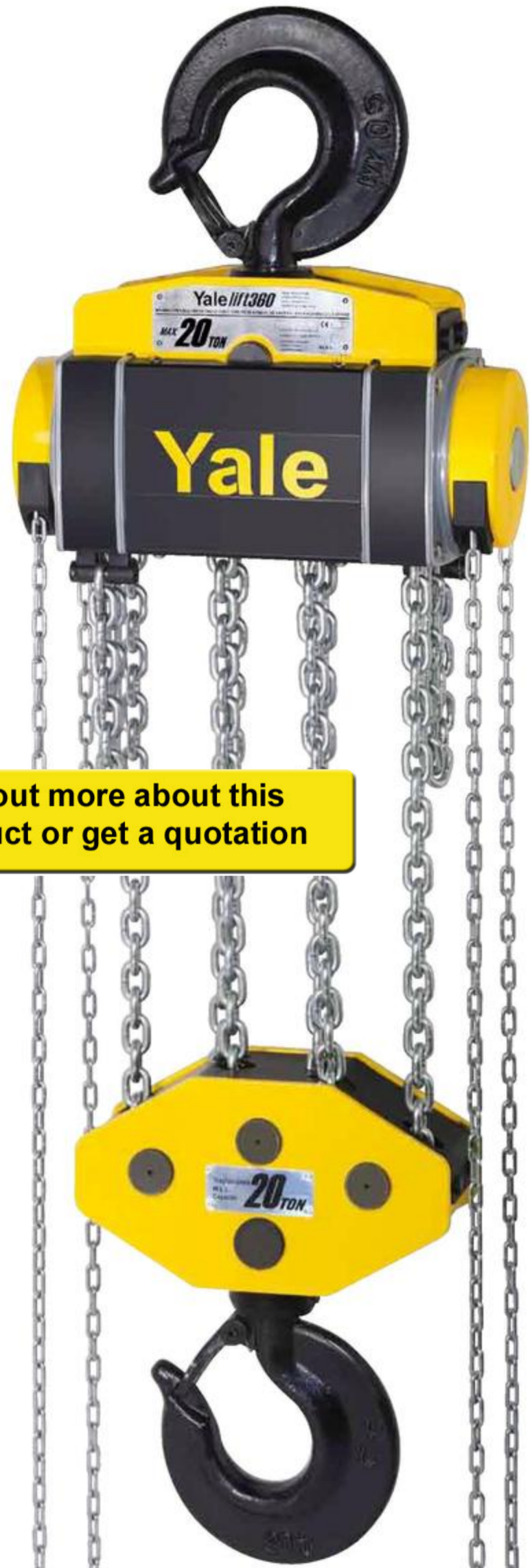

The robust stamped steel housing with four stay bolts is resistant to the toughest working conditions.



The precisely machined load sheave ensures accurate movement of the load chain.

! Yale hoists and trolleys are not designed for passenger elevation applications and must not be used for this purpose.

DLHONLINE

Technical data model Yalelift

Model	EAN-No. 4025092*	Capacity kg	Number of chain falls	Chain dimensions d x p mm	Lift per 1 m hand chain overhaul mm	Pull on hand chain at WLL daN	Weight at standard lift (3 m) kg
YL 500	*288545	500	1	5x15	33	21	9
YL 1000	*288552	1000	1	6x18	20	30	13
YL 2000	*288569	2000	1	8x24	14	32	20
YL 3000	*941129	3000	1	10x30	12	38	29
YL 5000	*941143	5000	2	10x30	6	34	38
YL 10000	*291842	10000	3	10x30	4	44	71
YL 20000	*292153	20000	6	10x30	2	2x44	196

► Find out more about this product or get a quotation



DLHONLINE

Dimensions model Yalelift

Model	YL 500	YL 1000	YL 2000	YL 3000	YL 5000	YL 10000	YL 20000
A min., mm	300	335	395	520	654	825	1065
B, mm	17	22	30	38	45	68	85
C, mm	24	29	35	40	47	68	64
D, mm	133	156	182	220	220	220	303
E, mm	148	175	203	250	250	383	555
F, mm	148	167	194	219	219	219	250
G, mm	139	164	192	225	242	326	391
H, mm	206	242	283	335	352	436	501
I, mm	24	24	31	34	21	136	-
K, mm	61	70	83	95	95	95	396
L, mm	87	97	111	124	124	124	125
M, mm	110	125	156	178	285	401	471
N, mm	14	19	22	30	37	50	56

Find out more about this product or get a quotation

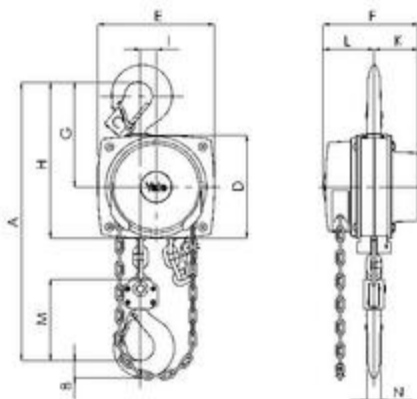

Model Yalelift 360, 500 - 3000kg, single fall

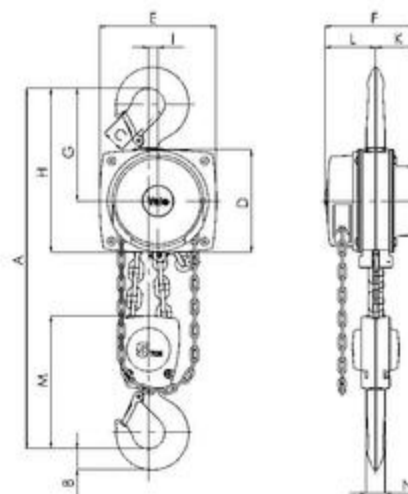

Model Yalelift 360, 5000kg, double fall

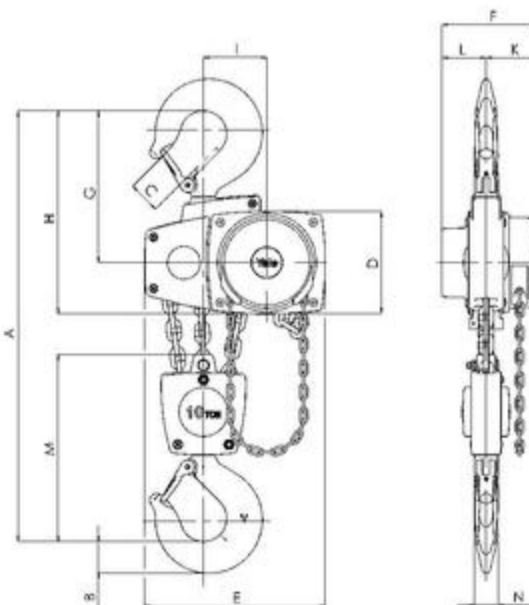

Model Yalelift 360, 10000kg, three fall

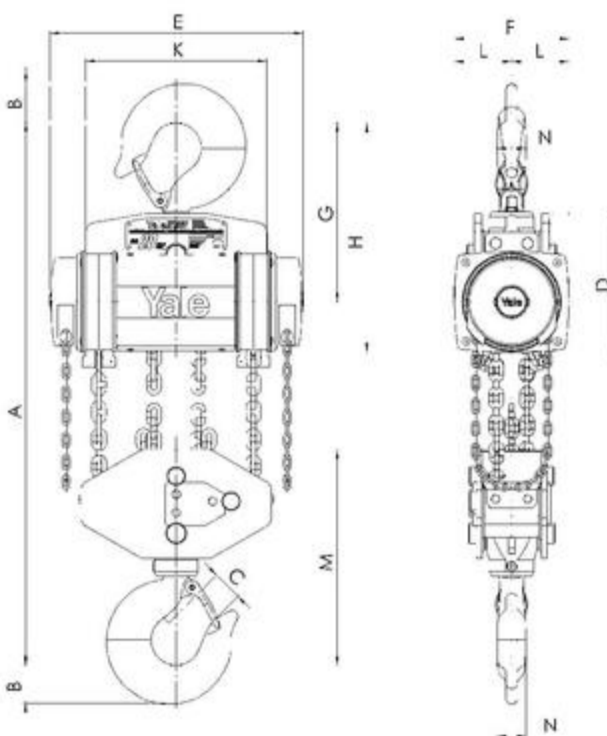

Model Yalelift 360, 20000kg, six fall

DLHONLINE



Hand chain hoist model Towerlift

Capacity 1000 - 2000 kg

The Towerlift is the inverted version of the Yalelift 360 and specifically designed for operation on traversing tower systems.

Features

- The unit is provided with a special chain guide and a totally enclosed housing.
- The basic version of the Towerlift offers capacities of 1000 kg and 2000 kg.
- Black powder coat finish as standard.
- Alloyed steel link chain with zinc-plated resp. yellow chromated finish, in accordance with national and international standards and regulations.

Options

- Adjustable overload prevention device.
- Stainless steel load and hand chains.
- Chain container

! Different colours, capacities and lifting heights are available on request.

Technical data model Towerlift

Model	EAN-No. 4025092*	Capacity kg	Number of chain falls	Chain dimensions d x p mm	Lift per 1 m hand chain overhaul mm	Pull on hand chain at WLL daN	Weight at standard lift (3 m) kg
Towerlift 1000	*079815	1000	1	6 x 18	20	30	14
Towerlift 2000	*079822	2000	1	8 x 24	14	32	21

Dimensions model Towerlift

Model	Towerlift 1000	Towerlift 2000
A min., mm	335	395
B, mm	22	30
C, mm	29	35
D, mm	156	182
E, mm	205	243
F, mm	167	194
G, mm	164	192
H, mm	242	283
I, mm	24	31
K, mm	70	83
L, mm	97	111
M, mm	125	156
N, mm	19	22

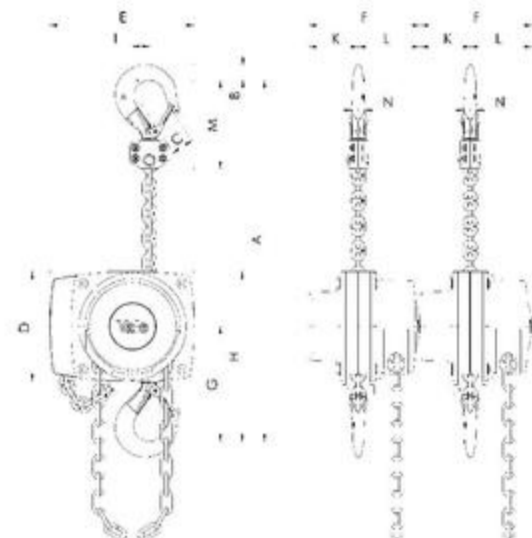

DLHONLINE

Hand chain hoist model VSIII

Capacity 250 - 5000 kg

The newly designed hand chain hoist VSIII is an innovative further development introduced by Yale. The improved hand chain guide prevents canting or jamming of the hand chain, leading to a smooth running of the chain. High quality bearings on side plates, gearbox and load chain sheave ensure smooth operation of load chain and drive pinion.

Optimized hand forces set standards for easy operation.

Features

- Strong bolts between side plates and housing cover and the reinforced hand wheel cover ensure increased stability.
- Precision machined guide rollers ensure smooth running of the load chain.
- High quality bearings for gearbox, side plates and load chain sheave permit a long service life.
- Zinc-plated and yellow-chromated brake parts and guide rollers ensure increased corrosion protection.
- Zinc-plated load chain as standard for added corrosion protection.

Options

- Overload prevention device
- Chain container



Find out more about this product or get a quotation



Load chain sheave with needle bearing

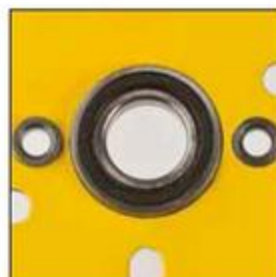

Side plate with ball bearing



Housing cover with ball bearing

! Yale hoists and trolleys are not designed for passenger elevation applications and must not be used for this purpose.

DLHONLINE

Technical data model VSIII

Model	EAN-No. 4025092*	Capacity in kg/ number of chain falls	Chain dimensions d x p mm	Lift per 1 m hand chain overhaul mm	Pull on hand chain at WLL daN	Weight at standard lift (3 m) kg
VSIII 0,25/1	*665322	250/1	4x12	50	20	3.9
VSIII 0,5/1	*949545	500/1	5x15	26	21	9.0
VSIII 1,0/1	*949927	1000/1	6x18	24	24	11.5
VSIII 1,5/1	*593854	1500/1	8x24	17	30	17.5
VSIII 2,0/1	*949934	2000/1	8x24	19	32	19.0
VSIII 2,0/2	*949941	2000/2	6x18	15	29	17.3
VSIII 3,0/1	*949958	3000/1	10x30	12	40	31.0
VSIII 3,0/2	*949965	3000/2	8x24	10	37	27.0
VSIII 5,0/2	*949972	5000/2	10x30	8	41	43.0

Dimensions model VSIII

Model	VSIII 0,25/1	VSIII 0,5/1	VSIII 1,0/1	VSIII 1,5/1	VSIII 2,0/1	VSIII 2,0/2	VSIII 3,0/1	VSIII 3,0/2	VSIII 5,0/2
A min., mm	290	350	380	450	460	490	570	580	700
B, mm	12	21	28	33	36	36	45	45	47
C, mm	26	23	27	36	35	35	40	40	45
D, mm	11	16	20	22	29	29	29	29	40
E, mm	118	145	158	180	205	170	240	220	250
F, mm	113	140	155	175	180	155	210	175	190
G, mm	65	80	87	85	94	87	110	94	95
H, mm	48	60	68	90	86	68	100	81	95
K, mm	190	240	270	300	320	285	370	340	410

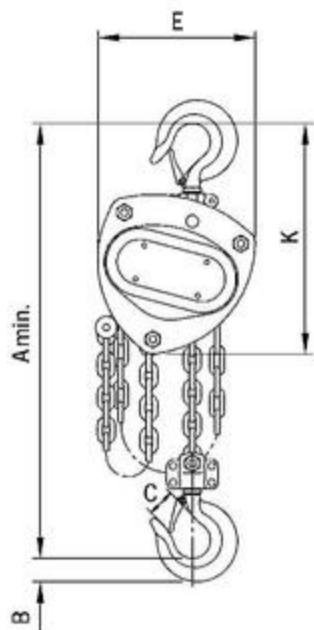

Model VSIII, 250 - 3000 kg, single fall

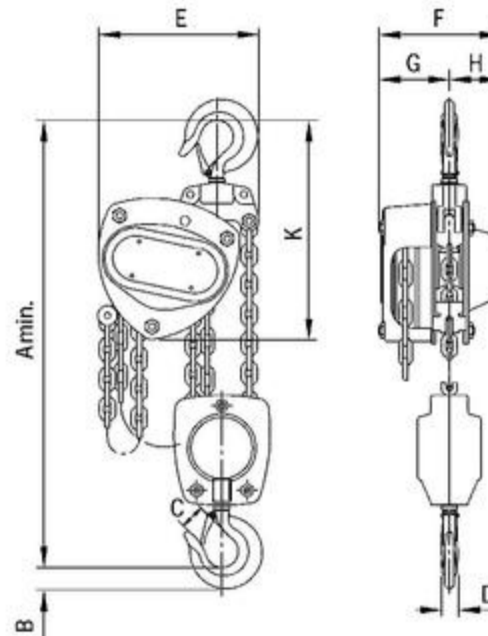

Model VSIII, 2000 - 5000 kg, double fall



Option: Chain container



Find out more about this product or get a quotation

DLHONLINE



Depicted rubber buffers optionally available.

Hand chain hoist with integrated push or geared type trolley model Yalelift IT

Capacity 500 - 20000 kg

The combination of the Yalelift 360 with a low headroom manual trolley provides even more flexibility in the application of the Yalelift 360.

Features

- All units of this series up to a capacity of 3000 kg are provided with single chain fall and the min. headroom (Dim. A) has been further reduced. Ideal for applications with low ceilings and limited headroom.
- The proven and almost stepless adjustment system allows quick and easy assembly of the trolley.
- Trolleys up to 5 t are offered for two beam ranges. Range A for a flange width up to 180 mm is standard and covers approx. 80% of all requirements. Conversion to range B for beam width up to 300 mm can be easily accomplished.
- The trolley wheels are designed for a max. beam profile incline of 14% (DIN 1025 - part 1), excellent rolling features are guaranteed by prelubricated, encapsulated ball bearings.
- Anti-drop and anti-tilt devices as standard.

Options

- Adjustable overload prevention device.
- Stainless steel load and hand chains.
- Chain container
- Rubber buffers
- Corrosion resistant version
- Explosion proof version
- Beam locking device to secure the unloaded trolley in a fixed position on the beam (park position e.g. on ships). Available up to a capacity of 5000 kg.



Available in explosion proof version. <<



Find out more about this product or get a quotation

DLHONLINE

Technical data model Yalelift IT

Model	EAN-No. 4025092*	Capacity in kg/ number of chain falls	Size	Beam flange width b	Beam flange thickness t max.	Curve radius min.	Weight at standard lift (3m) - P	Weight at standard lift (3m) - G	Weight at standard lift (3m) with locking device - P	Weight at standard lift (3m) with locking device - G
				mm	mm	m	kg	kg	kg	kg
YLIT 500	*288255	500/1	A	50 - 180	19	0.9	20	24	26	31
YLIT 500	-	500/1	B	180 - 300	19	0.9	21	25	27	32
YLIT 1000	*292221	1000/1	A	50 - 180	19	0.9	27	32	35	40
YLIT 1000	-	1000/1	B	180 - 300	19	0.9	29	33	37	41
YLIT 2000	*291798	2000/1	A	58 - 180	19	1.15	44	49	52	57
YLIT 2000	-	2000/1	B	180 - 300	19	1.15	46	50	54	58
YLIT 3000	*291804	3000/1	A	74 - 180	27	1.5	77	82	86	91
YLIT 3000	-	3000/1	B	180 - 300	27	1.4	79	84	88	93
YLIT 5000	*291828	5000/2	A	98 - 180	27	2.0	125	130	135	140
YLIT 5000	-	5000/2	B	180 - 300	27	1.8	129	134	139	144
YLIT 10000	*080996	10000/3	B	125 - 310	40	1.8	-	on request	-	on request
YLIT 20000**	*172325	20000/6	B	180 - 310	40	5.0	-	on request	-	on request

**Dimensions on request

P in connection with weight = with pushed trolley

G in connection with weight = with geared trolley



Chain guide



High quality encapsulated ball bearings and sliding bushes for smooth and effortless operation.

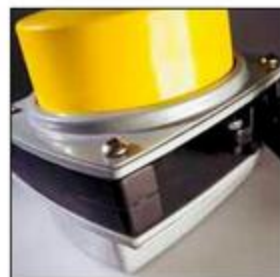

The robust stamped steel housing with four stay bolts is resistant to the toughest working conditions.



The precisely machined load sheave ensures accurate movement of the load chain.

Find out more about this product or get a quotation

! Yale hoists and trolleys are not designed for passenger elevation applications and must not be used for this purpose.

Dimensions model Yalelift IT

Model	YLIT 500	YLIT 1000	YLIT 2000	YLIT 3000	YLIT 5000	YLIT 10000
A min., mm	245	272	323	382	550	784
A1, mm	158	178	205.5	252	260.5	380
A2, mm	-	-	-	-	-	-
B, mm	17	22	30	38	45	68
C, mm	24	29	35	40	47	68
D, mm	14	19	22	30	37	50
F (Geared trolley), mm	92	92	91	107	149.5	113
H1, mm	24.5	24	23.5	32	30.5	55
I (Pushed trolley), mm	71.5	71.5	95.5	131	142.5	169
I (Geared trolley), mm	76.5	76.5	98	132.5	148.5	169
L, mm	270	310	360	445	525	430
L1, mm	130	130	150	180	209	200
L2, mm	159	175	207	256	283	261
L3, mm	-	-	-	-	-	-
L4, mm	-	-	-	-	-	-
M, mm	M18	M22	M27	M30	M42	M48
O, mm	60	60	80	112	125	150
P (Geared trolley), mm	108	110	112	112	117	158
T (Area A), mm	280	290	305	320	364	-
T (Area B), mm	400	410	425	440	484	540

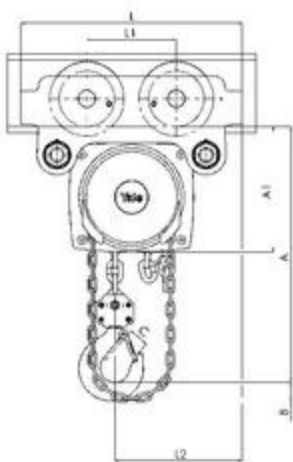

Model Yalelift ITP, 500 - 3000 kg, single fall

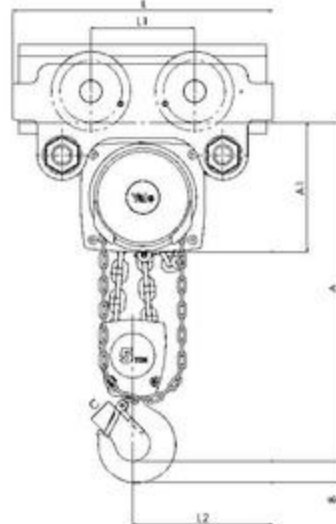
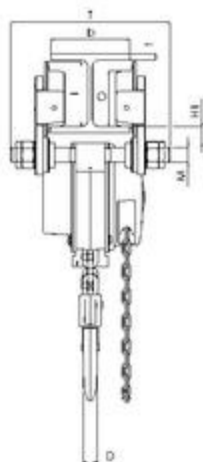

Model Yalelift ITP/ITG, 5000 kg, double fall

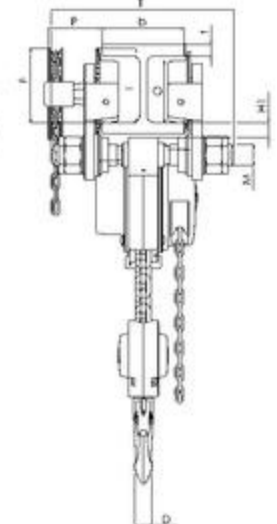
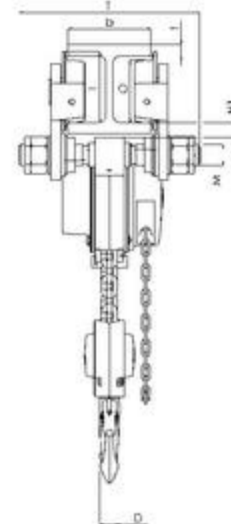

Find out more about this product or get a quotation

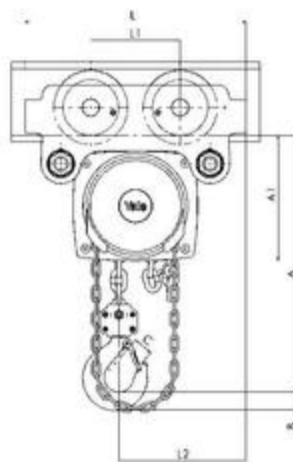

Model Yalelift ITG, 500 - 3000 kg, single fall

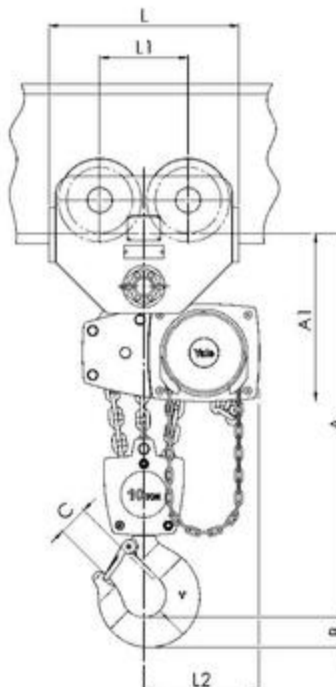
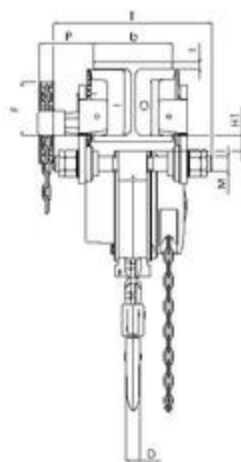

Model Yalelift ITG, 10000 kg, three fall

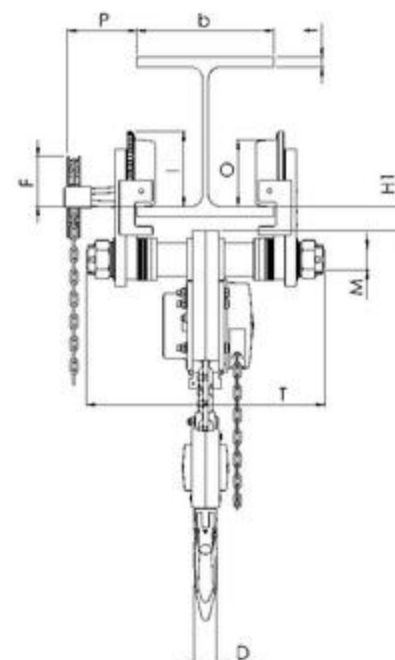

DLHONLINE

Hand chain hoist
with integrated push or geared
type trolley (low headroom)
model Yalelift LH

Capacity 500 - 10000 kg

The hand chain hoist model Yalelift LH with integrated low headroom manual trolley is the consequent further development of the Yalelift IT. Wherever an even smaller headroom is essential, the Yalelift LH is the ideal choice.

Features

- The specially developed chain reeving system and chain guide allow the bottom block to be pulled laterally to the hoist even further up and almost against the beam flange.
- The integrated design of the innovative Yalelift LH uses the same manual trolleys as incorporated in the Yalelift IT series.
- All models of the LH series up to 3000 kg capacity are provided with single chain fall.
- The proven and almost stepless adjustment system allows quick and easy assembly of the trolley.
- The trolleys up to 5t are offered for two beam ranges. Range A for a flange width up to 180 mm is standard and covers approx. 80% of all requirements. Conversion to range B for beam width up to 300 mm can be easily accomplished.
- The trolley wheels are designed for a max. beam profile incline of 14% (DIN 1025 - part 1), excellent rolling features are guaranteed by prelubricated, encapsulated ball bearings.
- The low headroom version of the Yalelift IT is adjustable to fit a wide range of beam profiles (e.g. INP, IPE, IPB).
- Anti-drop and anti-tilt devices as standard.
- Excellent rolling features due to machined steel wheels mounted on pre-lubricated, encapsulated ball bearings.

Options

- Adjustable overload prevention device.
- Stainless steel load and hand chains.
- Chain container
- Corrosion resistant version
- Explosion proof version
- Beam locking device to secure the unloaded trolley in a fixed position on the beam (park position e.g. on ships). Available up to a capacity of 5000 kg.



Available in explosion proof version. <<

Find out more about this product or get a quotation

Technical data model Yalelift LH

Model	EAN-No. 4025092*	Capacity in kg/ number of chain falls	Size	Beam flange width b	Beam flange thickness t max.	Curve radius min.	Weight at standard lift (3m) - P	Weight at standard lift (3m) - G	Weight at standard lift (3m) with locking device - P	Weight at standard lift (3m) with locking device - G
				mm	mm	m	kg	kg	kg	kg
YLLH 500	*293082	500/1	A	60 - 180	19	0.9	27	31	33	38
YLLH 500	-	500/1	B	180 - 300	19	0.9	27	32	34	38
YLLH 1000	*293167	1000/1	A	70 - 180	19	0.9	35	40	43	48
YLLH 1000	-	1000/1	B	180 - 300	19	0.9	36	41	44	49
YLLH 2000	*319676	2000/1	A	82 - 180	19	1.15	61	65	69	73
YLLH 2000	-	2000/1	B	180 - 300	19	1.15	62	67	70	75
YLLH 3000	*319669	3000/1	A	100 - 180	19	1.5	107	112	116	121
YLLH 3000	-	3000/1	B	180 - 300	19	1.4	109	114	118	123
YLLH 5000	*319652	5000/2	A	110 - 180	27	2.0	152	157	162	167
YLLH 5000	-	5000/2	B	180 - 300	27	1.8	156	161	166	171
YLLH 10000	-	10000/3	A	125 - 180	40	1.8	on request	230	on request	on request
YLLH 10000	-	10000/3	B	180 - 310	40	1.8	on request	232	on request	on request

P in connection with weight = with pushed trolley

G in connection with weight = with geared trolley

Find out more about this product or get a quotation

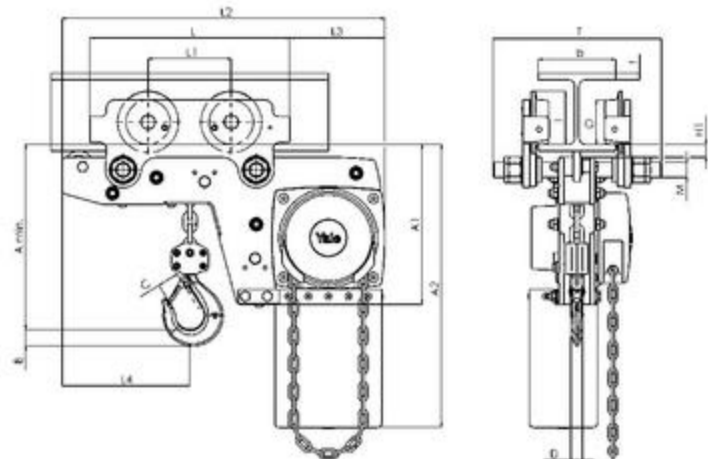

Model Yalelift LHP, 500 - 3000kg, single fall

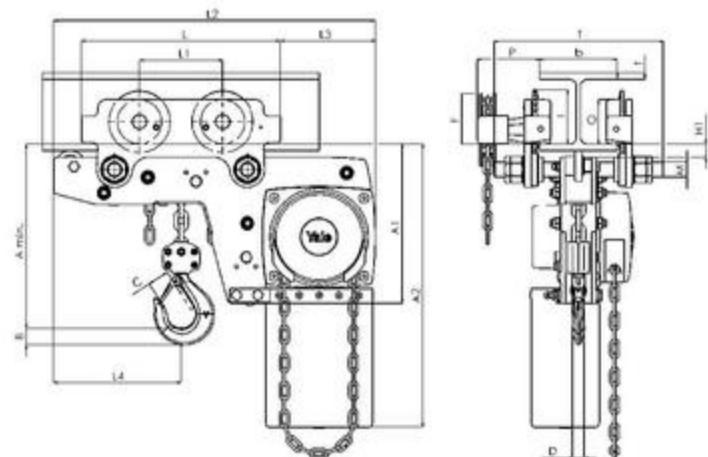

Model Yalelift LHG, 500 - 3000kg, single fall

Yale hoists and trolleys are not designed for passenger elevation applications and must not be used for this purpose.

DLHONLINE

Dimensions model Yalelift LH

Model	YLLH 500	YLLH 1000	YLLH 2000	YLLH 3000	YLLH 5000	YLLH 10000
A min., mm	188	211	264	316	425	565
A1, mm	223	250	289	346	345	365
A2, mm	381	427	511	614	612	665
B, mm	17	22	30	38	45	68
C, mm	24	29	35	40	47	68
D, mm	14	19	22	30	37	50
F (Geared trolley), mm	92	92	91	107	150	150
H1, mm	24	24	24	32	31	45
I (Pushed trolley), mm	72	72	96	131	143	170
I (Geared trolley), mm	77	77	98	133	149	170
L, mm	270	310	360	445	525	485
L1, mm	130	130	150	180	209	225
L2, mm	444	488	582	690	720	805
L3, mm	124	135	172	203	175	215
L4, mm	184	201	230	265	283	348
M, mm	M18	M22	M27	M30	M42	M48
O, mm	60	60	80	112	125	150
P (Geared trolley), mm	108	110	112	112	117	165
T (Area A), mm	280	290	305	320	364	440
T (Area B), mm	400	410	425	440	484	540

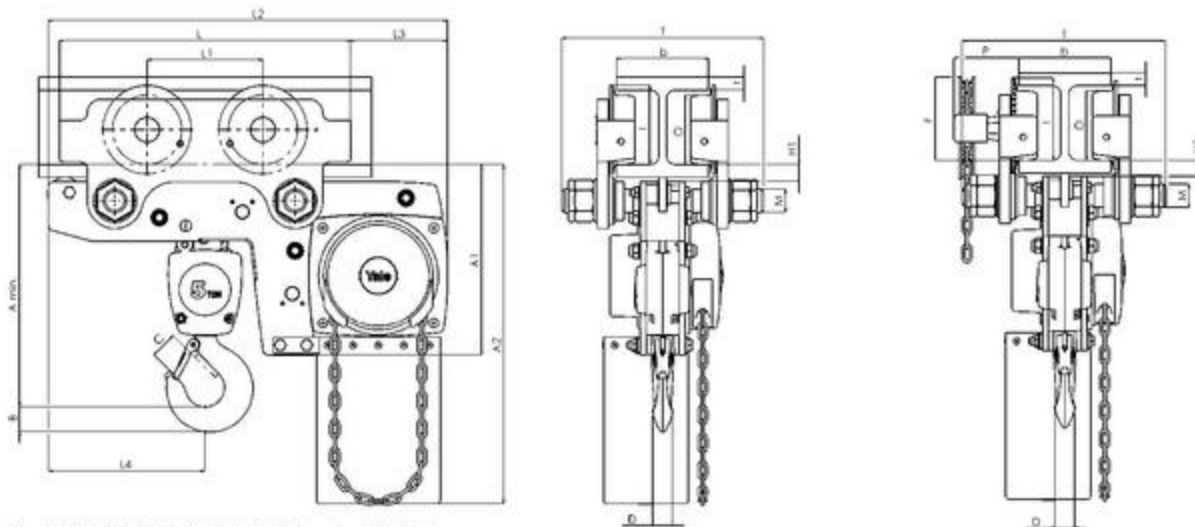

Model Yalelift LHP/LHG, 5000 kg, double fall

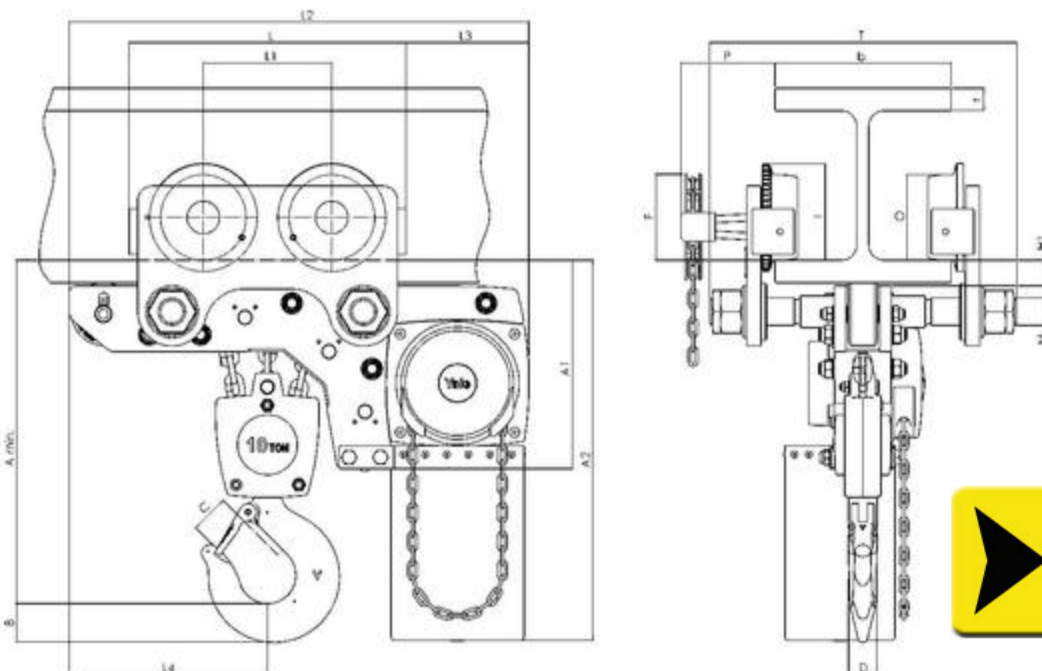

Model Yalelift LHG, 10000 kg, three fall

Find out more about this product or get a quotation

DLHONLINE



Find out more about this product or get a quotation



Corrosion protection CR

More life expectancy.

All models of the Yalelift programme can be supplied with corrosion resistant features which include zinc-plated load chain and stainless steel hand chain as standard.

Corrosion protection

Corrosion starts on the surface of components due to reaction of environmental influences. This affects the mechanical properties of the components, e.g. breaking load and total ultimate elongation.

Many components are supplied in black (unmachined), bright (machined) or painted condition. This offers certain protection but after only a short period of time corrosion can begin.

With the application of a protective coating, the development of corrosion can be reduced and delayed, thus extending the service life of the treated components.

Applications

Completely corrosion resistant units with either zinc-plated or stainless steel hand and load chains should be used in all conditions with increased requirements towards corrosion protection.

Typical applications are in food processing (e.g. dairy, abattoir, etc.), chemical industries (e.g. paper, dye industries), farming and sewage treatment.

Locking device

More grip.

Yale trolleys can be attached with a locking device to secure the unit. (Parking position, e.g. shipping industry).

Chain container

More comfort.

The chain containers for the Yalelift programme consist of a robust, powder-coated steel frame with a flexible chain bag made from high tensile Cordura textile fabric. Available in different sizes. Special sizes on request.

Overload protection

More control.

The overload protection device of the Yalelift programme reliably prevents excessive load take-up of the hoist during operation. The overload protection device provides additional safety with regard to possible false estimation of the load weight and thus increases the lifetime of the hoist.



All models available in explosion proof version!



DLHONLINE

Operation in explosion endangered environments.

More safety.

In nearly all industrial areas, and not only in the chemical industry, plants are operated in explosion endangered environments. Because of the great damage an explosion could cause to people and material values, special stringent legal and technical requirements are imposed on particularly electrical equipment used in explosion endangered environments (according to 94/9/EC).

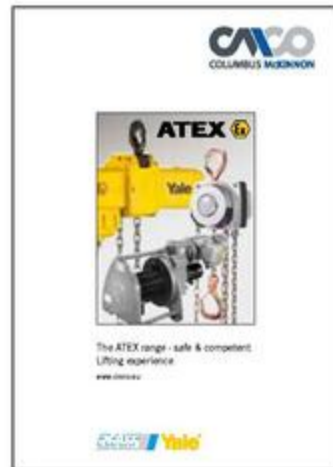

You would like to know more?
Simply ask for our ATEX-brochure.

[View ATEX Brochure <<](#)

Marking key

Example	CE	123	Ex	II	2	G	IIB	d	T3
---------	----	-----	----	----	---	---	-----	---	----

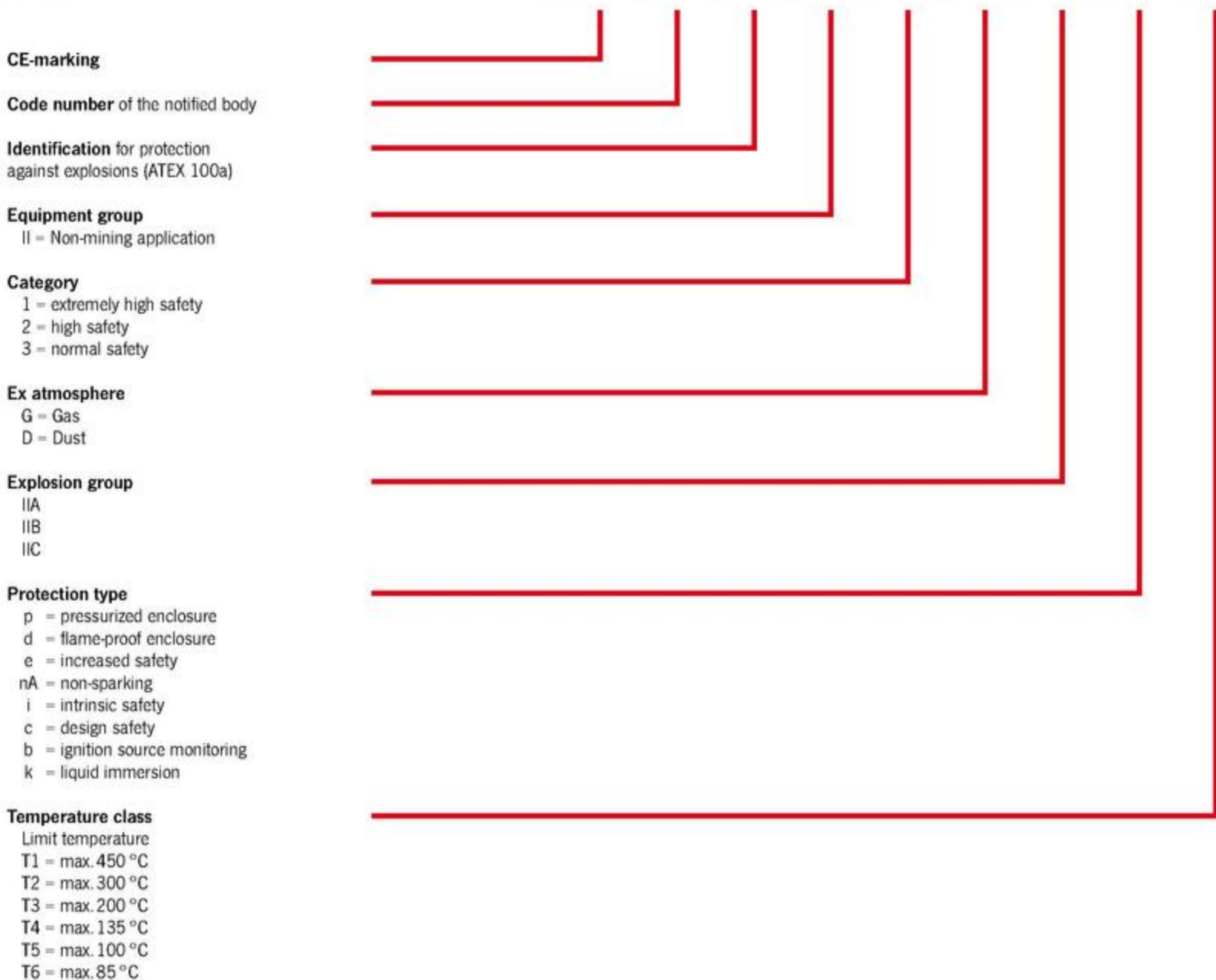

- CE-marking**
- Code number** of the notified body
- Identification** for protection against explosions (ATEX 100a)
- Equipment group**
II = Non-mining application
- Category**
1 = extremely high safety
2 = high safety
3 = normal safety
- Ex atmosphere**
G = Gas
D = Dust
- Explosion group**
IIA
IIB
IIC
- Protection type**
p = pressurized enclosure
d = flame-proof enclosure
e = increased safety
nA = non-sparking
i = intrinsic safety
c = design safety
b = ignition source monitoring
k = liquid immersion
- Temperature class**
Limit temperature
T1 = max. 450 °C
T2 = max. 300 °C
T3 = max. 200 °C
T4 = max. 135 °C
T5 = max. 100 °C
T6 = max. 85 °C

DLHONLINE

Applications

Paint factories, paint shops, foundries, on-/offshore, refineries, oil depots, electroplating, automobile factories, on ships and docks, printers, textile and paper industries, food industries, glass and ceramic industries, wood working industries and hardening shops etc.



Electro winch Model BETA-EX



[View ATEX Brochure <<](#)

Manual winch Model OMEGA-EX



Protection classifications are shown in our ATEX-brochure.



DLHONLINE

Hand chain hoists
& Trolleys
Model Yalelift 360 ATEX
Model Yalelift IT ATEX
Model Yalelift LH ATEX
Model HTP/G ATEX



[View ATEX Brochure <<](#)

Pneumatic chain hoists
Model CPA ATEX



Ratchet lever hoists
Model UNOplus ATEX



DLHONLINE



Swivel truck low headroom trolley hoist suitable for extreme curve radius model VLRP and model VLRG

Capacity 250 - 6000 kg

The hand chain hoist series VLR with integrated manual trolley drive features extremely low headroom capabilities and provides optimal usage of the available storage space in confined areas.

Hand wheel and gear case are positioned outside the reach of the bottom flange, thus allowing the bottom block to be raised almost until the underside of the beam. The swivel truck feature of the trolley suspension enables travelling on extremely short radius curves.

Features

- All-steel construction with zinc-plated load and hand chains.
- The integrated swivel truck trolley suspension permits application on runways with extremely narrow radii.
- All units are built to order for a predetermined beam dimension. They cannot be adjusted retro-actively to other beam sizes.
- Anti-drop and anti-tilt devices as standard.
- The rotating hand chain guide allows side-pull of the trolley hand chain in travel direction.

Options

- Overload prevention device.
- Chain container
- Buffers



Find out more about this product or get a quotation

! Yale hoists and trolleys are not designed for passenger elevation applications and must not be used for this purpose.



! Beam profile and dimension as well as curve radius must always be specified when ordering.

DLHONLINE

Compact low headroom trolley hoist with integrated manual trolley model VNRP and model VNRG

Capacity 1500 - 24000 kg

On account of a special chain reeving system and corresponding chain guide the trolley hoist series VNR offers minimum headroom and maximum usage of the available room height. These hoists have been specially designed for heavy industrial applications.

Features

- All-steel construction with zinc-plated load and hand chains.
- All units are built to order for a predetermined beam dimension. They cannot be adjusted retro-actively to other beam sizes.
- Anti-drop and anti-tilt devices as standard.

Options

- Chain container
- Buffers



Find out more about this product or get a quotation

extremely low headroom for confined spaces

! Beam profile and dimension as well as curve radius must always be specified when ordering.



Swivel truck trolley with low headroom and extremely short curve radius model VLHP and model VLHG

Capacity 250 - 6000 kg

The manual trolley series VLH features extremely low headroom. The swivel truck construction allows negotiation of very short curve radius.

Features

- All-steel construction with low headroom.
- All units are built to order for a predetermined beam dimension. They cannot be adjusted retro-actively to other beam sizes.
- Anti-drop and anti-tilt devices as standard.

Options

- Buffers
- Large variety of special versions.

DLHONLINE

▶ Find out more about this product or get a quotation



▶ Find out more about this product or get a quotation

Push and geared type trolley model HTP and model HTG

Capacity 500 - 20000 kg

The trolley enables the exact positioning or easy traversing of large loads with either manual or powered hoisting equipment.

Features

- It has excellent rolling features due to machined steel wheels mounted on prelubricated, encapsulated ball bearings.
- Adjustable to fit a wide range of beam widths and profiles (e.g. INP, IPE and IPB).
- Adjustments are made by rotating the clevis load bar which also ensures the centred positioning of the hoist in the clevis – no creeping to the left or the right.
- The trolley wheels are designed for a max. beam profile incline of 14% (DIN 1025 - part 1).
- Trolleys are in accordance with the UW and machinery directives.

Options

- Rotating hand chain guide.
- Stainless steel hand chains.
- Buffers
- Corrosion resistant version
- Explosion proof version
- Locking device to secure the trolley in position on the beam (park position e.g. on ships).

! Yale hoists and trolleys are not designed for passenger elevation applications and must not be used for this purpose.

DLHONLINE

Technical data model HTP and model HTG

Model	EAN-No. 4025092*	Capacity kg	Size	Beam flange width b mm	Beam flange thickness t max. mm	Curve radius min. m	Hand effort at WLL daN	Weight* kg	Weight* with locking device kg
HTP 500	*054874	500	A	50 - 220	25	0.9	-	8.0	14.5
HTP 1000	*054881	1000	A	50 - 220	25	0.9	-	9.0	17.0
HTP 2000	*054898	2000	A	66 - 220	25	1.15	-	16.0	24.0
HTP 3000	*054904	3000	A	74 - 220	25	1.4	-	32.0	41.2
HTP 5000	*054911	5000	A	90 - 220	25	1.8	-	48.0	58.5
HTP 500	*054928	500	B	160 - 300	40	0.9	-	10.6	17.1
HTP 1000	*054935	1000	B	160 - 300	40	0.9	-	12.0	20.0
HTP 2000	*054942	2000	B	160 - 300	40	1.15	-	19.3	27.3
HTP 3000	*054959	3000	B	160 - 300	40	1.4	-	35.8	45.0
HTP 5000	*054966	5000	B	180 - 300	40	1.8	-	52.2	62.7
HTG 500	*074711	500	A	50 - 220	25	0.9	3	9.7	16.2
HTG 1000	*074728	1000	A	50 - 220	25	0.9	6	11.2	19.2
HTG 2000	*074735	2000	A	66 - 220	25	1.15	7	18.0	26.0
HTG 3000	*074742	3000	A	74 - 220	25	1.4	7	35.4	44.6
HTG 5000	*074759	5000	A	90 - 220	25	1.8	9	51.8	62.3
HTG 500	*074766	500	B	160 - 300	40	0.9	3	12.6	19.1
HTG 1000	*074841	1000	B	160 - 300	40	0.9	6	14.1	22.1
HTG 2000	*074773	2000	B	160 - 300	40	1.15	7	21.3	29.3
HTG 3000	*074780	3000	B	160 - 300	40	1.4	7	39.2	48.4
HTG 5000	*074797	5000	B	180 - 300	40	1.8	9	56.0	66.5
HTG 8000	*074803	8000	B	125 - 310	40	1.8	14	104.0	-
HTG 10000	*074810	10000	B	125 - 310	40	1.8	14	104.0	-
HTG 15000	*074827	15000	B	125 - 310	40	5.0	29	230.0	-
HTG 20000	*074834	20000	B	125 - 310	40	5.0	29	230.0	-

*Weight HTG: without hand chain



Available in explosion proof version.

Dimensions model HTP

Find out more about this product or get a quotation

Model	HTP 500-A	HTP 1000-A	HTP 2000-A	HTP 3000-A	HTP 5000-A	HTP 500-B	HTP 1000-B	HTP 2000-B	HTP 3000-B	HTP 5000-B
A, mm	77	82.5	98.5	114	132.5	92	97.5	113.5	129	147.5
D, mm	16	17	22	26	33	16	17	22	26	33
D1, mm	25	30	40	48	60	25	30	40	48	60
D2, mm	30	35	47	58	70	30	35	47	58	70
F1, mm	46	46	46	46	45.5	46	46	46	46	45.5
H1, mm	30.5	30.5	30.5	30	30	45.5	45.5	45.5	45	45
l (HTP), mm	71.5	71.5	95.5	131	142.5	71.5	71.5	95.5	131	142.5
L, mm	260	260	310	390	450	260	260	310	390	450
L1, mm	130	130	150	180	209	130	130	150	180	209
O, mm	60	60	80	112	125	60	60	80	112	125
P1, mm	168	168	168	168	168	168	168	168	168	168
P2, mm	146	150	155	160	167.5	146	150	155	160	167.5
L3, mm	346	346	396	476	556	346	346	396	476	556

Dimensions model HTG

Find out more about this product or get a quotation

Model	HTG 500-A	HTG 1000-A	HTG 2000-A	HTG 3000-A	HTG 5000-A	HTG 500-B	HTG 1000-B	HTG 2000-B	HTG 3000-B	HTG 5000-B	HTG 8000-B	HTG 10000-B	HTG 15000-B	HTG 20000-B
A, mm	77	82.5	98.5	114	132.5	92	97.5	113.5	129	147.5	276	276	270	270
B, mm	-	-	-	-	-	-	-	-	-	-	52	52	70	70
D, mm	16	17	22	26	33	16	17	22	26	33	30	30	35	35
D1, mm	25	30	40	48	60	25	30	40	48	60	80	80	110	110
D2, mm	30	35	47	58	70	30	35	47	58	70	114	114	155	155
F (HTG), mm	91.5	91.5	90.5	107.5	149.5	91.5	91.5	90.5	107.5	149.5	113	113	113	113
F1, mm	46	46	46	46	45.5	46	46	46	46	45.5	77	77	-	-
H1, mm	30.5	30.5	30.5	30	30	45.5	45.5	45.5	45	45	45	45	45	45
l (HTG), mm	76.5	76.5	98	132.5	148.5	76.5	76.5	98	132.5	148.5	170	170	170	170
L, mm	260	260	310	390	450	260	260	310	390	450	430	430	870	870
L1, mm	130	130	150	180	209	130	130	150	180	209	200	200	200	200
L2, mm	-	-	-	-	-	-	-	-	-	-	-	-	115	115
O, mm	60	60	80	112	125	60	60	80	112	125	150	150	150	150
P (HTG), mm	110	110	110	110	110	110	110	110	110	110	163	163	163	163
P1, mm	168	168	168	168	168	168	168	168	168	168	193	193	-	-
P2, mm	146	150	155	160	167.5	187	187	189.5	191.5	191.5	-	-	-	-
T, mm	-	-	-	-	-	-	-	-	-	-	270	270	270	270
L3, mm	346	346	396	476	556	346	346	396	476	556	536	536	976	976
P3, mm	194	194	194	195	195	194	194	194	195	195	-	-	-	-

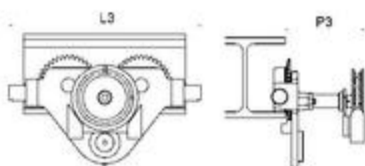

Model HTG 500 - 5000 kg with rotating hand chain guide and buffers

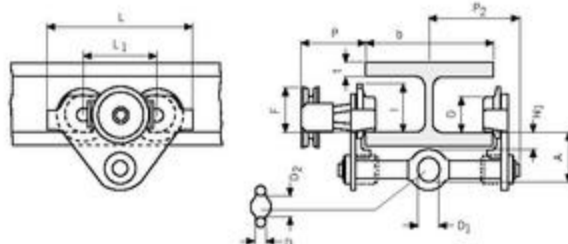

Model HTP/G 500 - 5000 kg

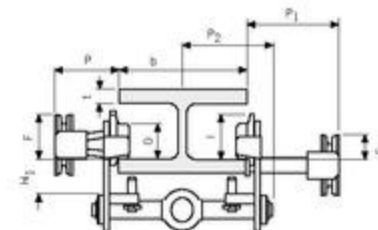

Model HTP/G 500 - 5000 kg, with locking device

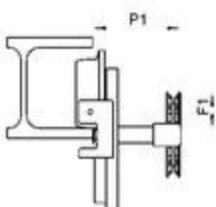

Model HTG 10000 kg, locking device

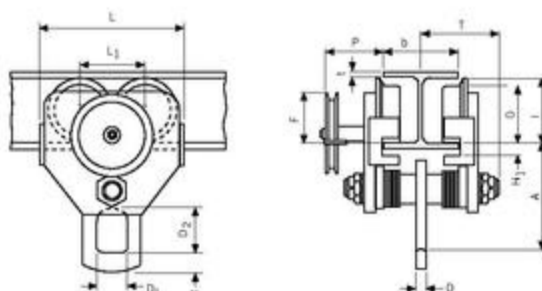

Model HTG 10000 kg

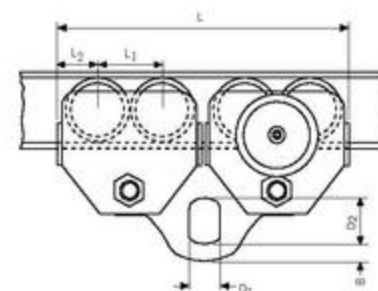

Model HTG 20000 kg

DLHONLINE

Trolley clamp model CTP

Capacity 1000 - 3000 kg

Easy fitting to overhead beams for the attachment and transport of loads.

Features

- Central threaded spindle provides quick adjustment to the required beam width.
- Threaded spindle and clevis are zinc-plated for added corrosion protection.



Find out more about this product or get a quotation

Technical data model CTP

Model	EAN-No. 4025092*	Capacity kg	Beam flange width b mm	Curve radius min. m	Weight kg
CTP 1-A	*063012	1000	60 - 150	0.6	2.5
CTP 2-A	*055437	2000	75 - 200	0.9	9.9
CTP 2-B	*055444	2000	200 - 300	0.9	10.3
CTP 3-A	*055451	3000	75 - 200	1.15	17.5
CTP 3-B	*055468	3000	200 - 320	1.15	19.5

Dimensions model CTP

Model	CTP 1-A	CTP 2-A	CTP 2-B	CTP 3-A	CTP 3-B
A, mm	82 - 109	106 - 155	136 - 191	128 - 171	150 - 212
D, mm	26	42	42	50	50
E, mm	22	20	20	22	22
H1, mm	20	24	24	30.5	30.5
l, mm	53	71.5	71.5	95.5	95.5
L, mm	160	260	260	310	310
L1, mm	75	130	130	150	150
M, mm	M12	M18	M18	M24	M24
O, mm	46	60	60	80	80
P, mm	153	205	255	220	280
T, mm	105	139	189	155	215
tmax., mm	15	25	25	25	25

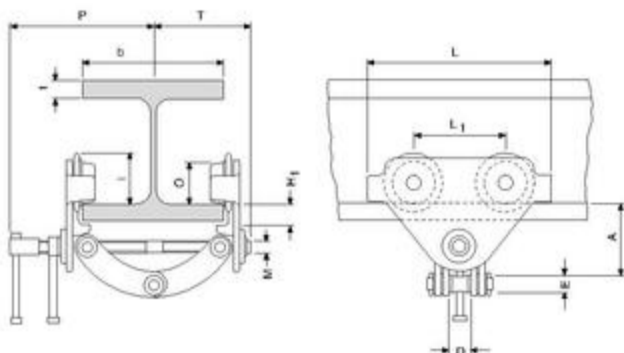

! Yale hoists and trolleys are not designed for passenger elevation applications and must not be used for this purpose.

DLHONLINE



Electric trolley model VTE-U

Capacity 1000 - 5000 kg

Specially recommended for loads over 1000kg, for transporting over long distances and/or when used frequently. Suitable for almost all hoists with suspension hook due to universal shackle connection.

Travel motor with worm gear transmission ensures smooth start and self braking – a separate motor brake is not required.

Features

- Standard operating voltage:
Euro-voltage 400V, 3-phase, 50 Hz.
Single speed motors can be reconnected to 230V.
- Motor protected to IP 55 against dust and water jets.
Push-button pendant control, IP 65.
- Compact, robust frame with low overall height.
- Wheels manufactured from fracture-proof steel. Smooth running due to machined surfaces and ball bearing mounting. Cambered profile suitable for parallel and inclined beam profiles.
- Anti-drop and anti-tilt devices as standard.
- Easy adjusted to fit to a wide range of beam widths and profiles due to threaded spindles.

Options

- Low voltage control (42V)
- Rubber buffers
- 230V, 1-phase, 50 Hz

Find out more about this product or get a quotation



Wheel with cambered profile



Threaded spindle



Anti-drop device with option to fit buffers.

DLHONLINE

Technical data model VTE-U

Model	EAN-No. 4025092*	Capacity kg	Travel speed m/min	Motor kW	Beam flange width mm	Beam flange thickness t max. mm	Curve radius min. m	Weight kg
VTE 1-A-18/U*	*073547	1000	18 or 18/4.5	0.18 or 0.18/0.06	58 - 180	19	0.9	19.5
VTE 1-B-18/U*	*073585	1000	18 or 18/4.5	0.18 or 0.18/0.06	180 - 300	19	0.9	25.2
VTE 2-A-18/U*	*073561	2000	18 or 18/4.5	0.18 or 0.18/0.06	58 - 180	19	1.15	26.0
VTE 2-B-18/U*	*073608	2000	18 or 18/4.5	0.18 or 0.18/0.06	180 - 300	19	1.15	30.2
VTE 3-A-11/U	*073424	3000	11 or 11/2.8	0.37 or 0.3/0.09	74 - 180	27	1.5	51.0
VTE 3-B-11/U	*073509	3000	11 or 11/2.8	0.37 or 0.3/0.09	180 - 300	27	1.4	53.0
VTE 5-A-11/U	*073448	5000	11 or 11/2.8	0.37 or 0.3/0.09	98 - 180	27	2.0	77.0
VTE 5-B-11/U	*073523	5000	11 or 11/2.8	0.37 or 0.3/0.09	180 - 300	27	1.8	80.0

*11 or 11/2.8m/min. travel speed on request

Dimensions model VTE-U

Model	VTE 1-A-18/U	VTE 1-B-18/U	VTE 2-A-18/U	VTE 2-B-18/U	VTE 3-A-11/U	VTE 3-B-11/U	VTE 5-A-11/U	VTE 5-B-11/U
A, mm	113	113	115	115	139	139	161	161
B, mm	b + 50	b + 50	b + 54	b + 54	b + 60	b + 60	b + 70	b + 70
C, mm	49	49	47	47	57	57	60	60
D, mm	16	16	16	16	19	19	22	22
E, mm	187	187	187	187	202	202	202	202
F, mm	94	94	94	94	94	94	94	94
G, mm	43	43	43	43	51	51	58	58
H, mm	129	129	128	128	144	144	178	178
H1, mm	24	24	24	24	32	32	32	32
I, mm	77	77	98	98	133	133	149	149
L1, mm	130	130	150	150	180	180	209	209
M, mm	155	155	180	180	208	208	263	263
N single speed, mm	255	255	255	255	292	292	292	292
N double speed, mm	263	263	263	263	296	296	296	296
O, mm	60	60	80	80	112	112	125	125
P, mm	123	123	123	123	129	129	121	121
Q, mm	145	205	153	213	160	220	182	242

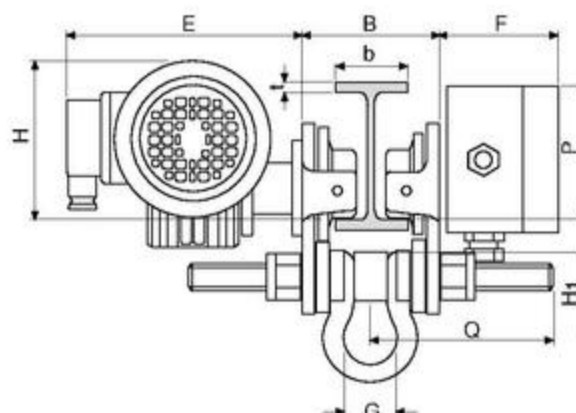
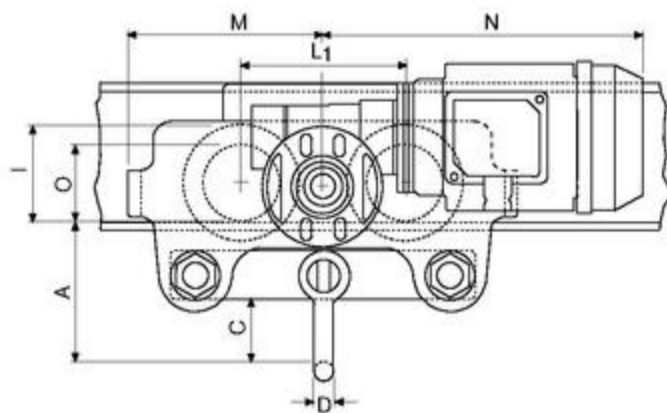

! Yale hoists and trolleys are not designed for passenger elevation applications and must not be used for this purpose.

▶ Find out more about this product or get a quotation

DLHONLINE



Beam clamp model YRC

Capacity 1000 - 10000 kg

Compact and rigid beam clamp to be used as a versatile rigging point for hoisting equipment and loads.

Flexible application due to wide adjustment range.

The central threaded spindle allows easy attachment and a safe and secure grip. The spindle can be secured against loosening.

Features

- Extremely robust due to reinforced side plates and jaws, for a safe attachment point even under demanding conditions.
- Easy handling due to proven threaded spindle mechanism.
- Flattened clamping jaws for use even in confined spaces.

Technical data model YRC

Model	EAN-No. 4025092*	Capacity kg	Beam flange width mm	Weight kg
YRC 1	*080682	1000	75 - 230	4.8
YRC 2	*080699	2000	75 - 230	6.2
YRC 3	*080705	3000	80 - 320	12.6
YRC 5	*080712	5000	90 - 320	14.3
YRC 10	*080729	10000	90 - 320	24.0

Yale hoists and trolleys are not designed for passenger elevation applications and must not be used for this purpose.

Dimensions model YRC

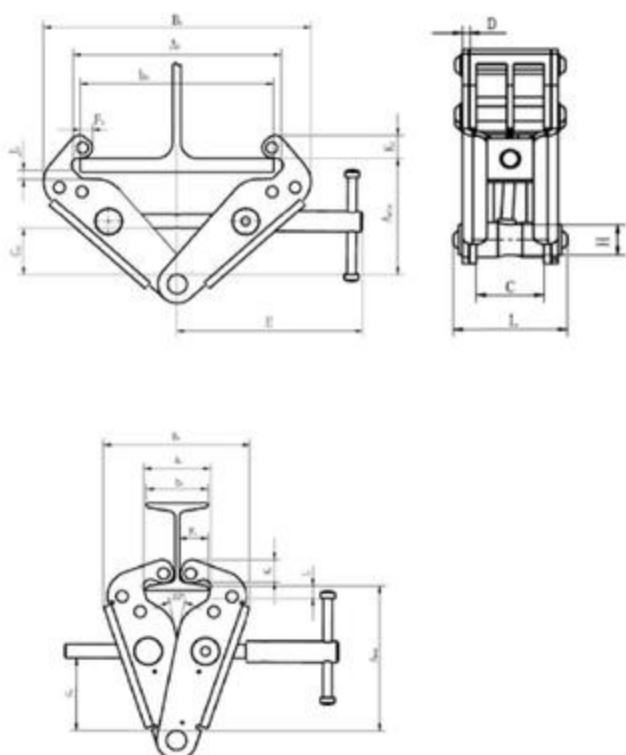

Model	YRC 1	YRC 2	YRC 3	YRC 5	YRC 10
A min., mm	135	135	183	183	202
A max., mm	165	165	224	224	241
A1, mm	74	74	97	97	114
A2, mm	238	238	330	330	340
B1, mm	161	163	212	216	263
b1, mm	68	68	80	80	90
B2, mm	300	304	425	425	475
b2, mm	230	230	320	320	320
C, mm	45	58	69	69	69
D, mm	4	6	8	10	12
E, mm	212	212	303	303	304
F1, mm	32	32	37	37	40
F2, mm	19	19	30	30	31
G1, mm	83	83	118	118	112
G2, mm	53	53	79	79	80
H, mm	20	20	32	32	44
J1, mm	14	14	22	22	27
J2, mm	26	26	37	37	41
K1, mm	26	26	41	41	53
K2, mm	26	26	32	32	40
L, mm	77	97	117	125	133



Find out more about this product or get a quotation

DLHONLINE

Beam clamp model YC

Capacity 1000 - 10000 kg

Provides a quick and versatile rigging point for hoisting equipment, pulley blocks or loads. Flexible application due to wide adjustment range. The central threaded spindle allows easy attachment and a safe and secure grip. The spindle can be secured against loosening.

Options

- Can be supplied with shackle (other jaw capacities).



Find out more about this product or get a quotation

Technical data model YC

Model	EAN-No. 4025092*	Capacity kg	Beam flange width mm	Weight kg
YC 1	*055154	1000	75 - 230	3.8
YC 2	*055161	2000	75 - 230	4.6
YC 3	*055192	3000	80 - 320	9.2
YC 5	*055208	5000	90 - 320	11.0
YC 10	*055215	10000	90 - 320	17.2

Yale hoists and trolleys are not designed for passenger elevation applications and must not be used for this purpose.

Dimensions model YC

Model	YC 1	YC 2	YC 3	YC 5	YC 10
A min., mm	115	115	180	180	175
A max., mm	150	150	225	225	220
A1, mm	78	78	80	90	90
A2, mm	246	246	320	310	320
B1, mm	186	186	232	242	268
B2, mm	350	350	455	445	480
b1, mm	75	75	80	90	90
b2, mm	230	230	320	310	320
C, mm	50	50	70	70	70
D, mm	4	6	8	10	14
E, mm	215	215	255	255	275
F1, mm	34	35	35	35	35
F2, mm	17	18	21	21	20
G1, mm	82	82	120	116	110
G2, mm	44	44	75	75	66
H, mm	20	20	22	28	38
J1, mm	14	14	30	30	34
J2, mm	21	21	34	34	35
K1, mm	48	50	60	60	60
K2, mm	31	32	40	42	40
L, mm	84	94	122	129	146

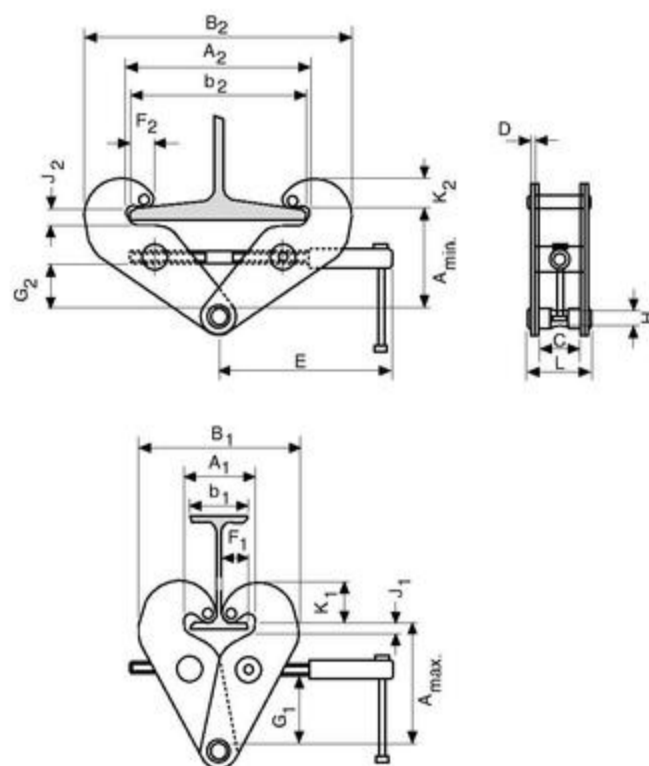

Also useable as a horizontal rigging point. Also applicable as lifting clamp.

DLHONLINE

General information about electric chain hoists

Apart from the usual criterion such as lifting capacity, lifting speed and dimensions also consider following:

1. Choosing a motor according to FEM 9.683

In addition to the torque the decisive criterion for rating an electric motor is the heat it generates. Here we differentiate between two operational modes:

1.1 Intermittent duty

In this case the motor is designed for a series of equal cycles consisting of duty periods with constant load and rest periods. The heat generation depends on the relative duty cycle, that is, the relationship between operating period under load, total operating time and the number of starts/hour.

$$ED = \frac{\text{Operating period}}{\text{Operating period} + \text{rest periods}} \%$$

The number of cycles that can be made under full load is calculated as follows:

$$S \approx 0.3 \times \frac{ED \times V}{H}$$

- S = Cycles per hour
- ED = Duty rating in %
- V = Lifting speed in m/min
- H = Average lifting height in m

A cycle consists of a motion of lifting, lowering and the rest periods. One must ensure that the lifting height does not exceed the value permitted by the percentage duty cycle referred to a cycle period of 10 minutes

$$H \leq \frac{ED \times V}{20}$$

and that simultaneously the permissible number of starts is not exceeded. It is generally accepted that a cycle consists of 6 starts.

1.2 Short time duty

Where special duty conditions exist (e.g. long hook path) the operating period must be of such length that the admissible temperature limit of the motor is not exceeded. For such cases intermittent duty must be replaced by short time duty. That is, the motor may be operated for up to 10 starts over a certain period (with Yale products 30 min). Thereafter the motor must cool down to room temperature.

1.3 Calculation example intermittent duty

Electric hoist	:	CPV 5-8
Lifting speed	:	8 m/min
Lifting height	:	2.8 m
Duty rating ED	:	50 %
c/h	:	180

Number of cycles per hour.

$$S = 0.3 \times \frac{50 \times 8}{20} = 42.8$$

Max. lifting height

$$H = 2.8 \leq \frac{50 \times 8}{20} = 20 \text{ m}$$

Number of starts

$$N = \frac{25 \text{ cycles}}{\text{hour}} \times \frac{6 \text{ starts}}{\text{cycle}} = 150 \text{ c/h}$$

DLHONLINE

2. Classification of hoisting equipment according to FEM 9.511

To choose an optimal hoist the lifting capacity and also the classification group must be known. The classification group indicates the theoretical operating time of the mechanical components under full load:

Classification group	FEM ISO	1 Bm M3	1 Am M4	2 m M5	3 m M6
Operating time in h		400	800	1600	3200

If the hoist is operated as classified an actual operating time of around 10 years can be expected.

After this period a general overhaul is necessary.

To define the classification group following values must be determined:

2.1 Average operating time per day

The average operating time can be estimated or calculated as follows:

$$\text{Operating time/day} = \frac{2 \times \text{average hook path} \times \text{cycles /hour} \times \text{operating time/day}}{60 \times \text{lifting speed}}$$

2.2 Load spectrum

The load spectrum indicates to what extent a hoist or part thereof is subject to maximal stress or whether it is subject to smaller loads only. It can be calculated or estimated according to the diagrams on the right:

1 light
Hoists or parts thereof usually subject to very small loads and in exceptional cases only to maximum loads.

2 medium
Hoists or parts thereof usually subject to small loads but rather often to maximum loads.

3 heavy
Hoists or parts thereof usually subject to medium loads but frequently to maximum loads.

4 very heavy
Hoists or parts thereof usually subject to maximum or almost maximum loads.

2.3 Classification

The classification group is defined by operating hours and load spectrum:

Load spectrum	Aver. op. hours per working day		
1 light	up to 2	2-4	4-8
2 medium	up to 1	1-2	2-4
3 heavy	up to 0.5	0.5-1	1-2
4 very heavy	up to 0.25	0.25-0,5	0.5-1
Classification group acc. to FEM/ISO	1 Bm/M3	1 Am/M4	2 m/M5



IP protection according to EN 60529

Depending on the operating and environmental conditions the damaging effect of water, foreign particles and dust and the contact with live or moving parts inside a motor is to be prevented by choosing a suitable protection.

The marking used to indicate the degree of protection consists of the letters IP followed by two characteristic numerals.

The marking applies to the unit as it is supplied and the defined or usual location of the unit.

The protection can change if the unit is located or fitted differently.

Motor surface cooled

Protection	1 st digit	2 nd digit	
	Contact protection	Ingress of solid foreign particles	Ingress of liquid
IP 44	contact with tools or similar	against solid foreign bodies over 1 mm Ø	splashing from all directions
IP 50	complete protection against contact	damaging dust deposits	no protection
IP 54	contact with tools or similar	against solid foreign bodies over 1 mm Ø	splashing from all directions
IP 55	complete protection against contact	damaging dust deposits	water jets from all directions
IP 56	complete protection against contact	damaging dust deposits	momentarily flooding
IP 65	complete protection against contact	against ingress of dust	water jets from all directions

Protection against contact and solid foreign particles

First digit 0 No protection

No protection of persons against contact with live or moving parts inside the enclosure. No protection of equipment against ingress of solid foreign particles.

First digit 1 Protection against large solid foreign particles

Protection against accidental or inadvertent contact with live or moving parts inside the enclosure by a large surface of the human body, e.g. hand, but not protected against deliberate access to such parts.

First digit 2 Protection against med. size solid foreign particles

Protection against contact with live or moving parts inside the enclosure by fingers. Protection against ingress of medium size solid foreign particles of diameter greater than 12 mm.

First digit 3 Protection against small solid foreign particles

Protection against contact with live or moving parts inside the enclosure by tools, wires or such objects of thickness greater than 2.5 mm. Protection against ingress of small solid foreign particles of diameter greater than 2.5 mm.

First digit 4 Protection against granular structured foreign particles

Protection against contact with live or moving parts inside the enclosure by tools, wires or such objects of thickness greater than 1 mm. Protection against ingress of granular structured solid foreign particles of diameter greater than 1 mm.

First digit 5 Protection against dust deposits

Complete protection against contact with live or moving parts inside the enclosure. Protection against harmful deposits of dust. The ingress of dust is not totally prevented, but dust cannot enter in an amount sufficient to interfere with the satisfactory operation of the equipment enclosed.

First digit 6 Complete protection

Complete protection against contact with live or moving parts inside the enclosure. Protected against the ingress of dust.

Protection against liquids

Second digit 0 No protection

No particular protection

Second digit 1 Protection against vertical water drops

Droplets of condensed water falling on the enclosure shall have no harmful effects.

Second digit 2 Protection against diagonal falling water drops

Protection against dripping liquids. Droplets of falling liquid shall have no harmful effect when the enclosure is tilted at any angle up to 15° from the vertical.

Second digit 3 Protection against spray water

Protection against dripping liquids. Water falling as rain at an angle equal to or smaller than 60° in respect to the vertical shall have no harmful effect.

Second digit 4 Protection against splashing

Liquid splashed from any direction shall have no harmful effect.

Second digit 5 Protection against water jets

Water projected by a nozzle from any direction under stated conditions shall have no harmful effect.

Second digit 6 Protection against flooding

Protection against conditions on ships decks (deck watertight equipment). Water from heavy seas shall not enter the enclosure under prescribed conditions²⁾.

Second digit 7 Protection against immersion in water

It shall not be possible for water to enter the enclosure under stated conditions of pressure and time²⁾.

Second digit 8 Protection against indefinite immersion

Protection against indefinite immersion in water. Under specific pressure it shall not be possible for water to enter the enclosure²⁾.

²⁾ In certain cases water should not ingress. As required this is defined on the follow-on page of the unit in question.

DLHONLINE

Technical questionnaire for choosing a suitable electric chain hoist

Company: _____

Date: _____

Contact: _____

e-Mail: _____

Phone: _____

Fax: _____

Details about intended use

Required capacity

Lifting height

Ambient conditions

- Normal
- Humidity
- Dust
- Dirt
- Particular temperatures _____ °C
- Increased rel. humidity _____ %

Other

How long is the hoist in operation

- _____ Load cycles per hour
- _____ Hours per day
- _____ Days per week
- _____ Distance covered per lifting cycle

Unusual operating conditions that could be important for the choice and function of the electric chain hoist:

Type of load

- Permanent
- Changing
- Shocks
- Vibration
- Static

Trolley drive

- Motor
- Manual

Operating voltage

- 400 V
- 230 V
- 3-phase a.c.
- 1-phase a.c.

Power frequency

- 50 Hz
- 60 Hz

Protection

- IP54
- Other



DLHONLINE



Depicted chain container optionally available.

Electric chain hoist model CPS with suspension hook

Capacity 125 - 500 kg

The model CPS is the smallest and lightest model within the range of Yale electric chain hoists. Reliability and compact design make it ideal for numerous applications in the construction industry, service companies and many industrial areas for moving small and medium loads.

Features

- Classification: 1 Am/M4 (standard), resp. 1 Bm/M3 at 230V, 1-phase, 50 Hz. As required the model CPS (with appropriate changes to lifting capacity resp. duty cycle) can also be re-classified.
- The standard version comes with direct control.
- Two year warranty (excluding wear parts).
- Thermal overload protection as standard.
- Duty cycle 30% ED, resp. 25% ED. 230V, 1-phase, 50 Hz.
- Safe hold of the load even in case of electric failure due to electromagnetic, spring pressure brake.
- Standard operating voltage: Euro-voltage 400V, 3-phase, 50 Hz, resp. 125 kg also as 230V, 1-phase, 50 Hz version.
- Motor protected to IP 54, against ingress of dust and splashing.
- Push-button pendant control, IP 65 against ingress of dust and water jets from all directions.
- The overload protection (slip clutch) avoids overloading and extends the lifetime of the hoist.
- Robust aluminium housing, powder coated.
- Extremely low headroom
- The standard case hardened and zinc-plated link chain is matched perfectly to the load chain to guarantee smooth and precise chain motion. All requirements of national and international standards and regulations are fulfilled.
- The 10-pocket load sheave ensures smooth running of the chain and minimizes chain wear.
- Drop forged suspension and load hooks are made from non-aging, high tensile steel and fitted with robust safety latches.

 Find out more about this product or get a quotation

Options

- Stainless steel load chain (no reduction of working load limit).
- Robust chain container
- Low voltage control 48V
- Manual and electric trolleys.
- Connection to festooned cable systems.

DLHONLINE

Technical data model CPS

Model	EAN-No. 4025092*	Capacity in kg/ number of chain falls	Standard lifting height m	Chain dimensions d x p mm	Classification FEM/ISO	Lifting speed m/min	Hoist motor kW	Weight kg	Operating voltage
CPS 1-4	*076654	125/1	3	4x12.2	1 Bm/M3	4	0.10	11.5	230 V/1 Ph/50 Hz
CPS 1-10	*076661	125/1	3	4x12.2	1 Am/M4	10	0.25	11.5	400 V/3 Ph/50 Hz
CPS 2-6	*076678	250/1	3	4x12.2	1 Am/M4	6	0.28	11.5	400 V/3 Ph/50 Hz
CPS 5-3	*076685	500/2	3	4x12.2	1 Am/M4	3	0.28	12.5	400 V/3 Ph/50 Hz

Dimensions model CPS

Model	CPS 1-4	CPS 1-10	CPS 2-6	CPS 5-3
A, mm	276	276	276	303
B, mm	98	98	98	146
C, mm	159	159	159	159
D, mm	75	75	75	60
E, mm	76	76	76	91
F, mm	160	160	160	160
G, mm	227	227	227	227
H, mm	103	103	103	103
I, mm	52	52	52	52
J*, mm	1905	1905	1905	1905
X, mm	25	25	25	25
Y, mm	14	14	14	14
Z, mm	21	21	21	21

*Dimensions at standard lift (3 m).

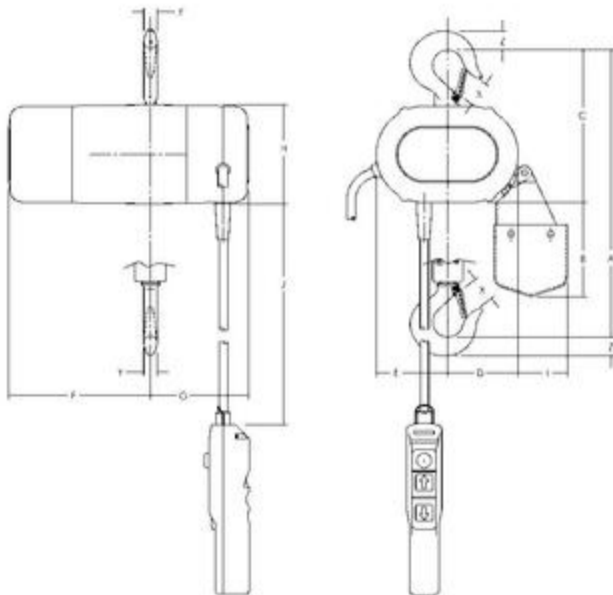

Smallest and lightest electric chain hoist for a great number of applications.

! Yale hoists and trolleys are not designed for passenger elevation applications and must not be used for this purpose.

▶ Find out more about this product or get a quotation

DLHONLINE



Electric chain hoist model CPV with suspension lug or with integrated trolley

Capacity 250 - 2000 kg

The electric chain hoist model CPV combines modern design and technical innovation. A robust construction makes the series a versatile tool for professional applications.

The integrated limit switch for the highest and lowest hook position considerably extends the working life span of the slip clutch, motor and gearbox.

Features

- Classification: 1 Am/M4 (standard), resp. 1 Bm/M3 (for 230 V, 1-phase, 50 Hz). As required (with appropriate changes to lifting capacity resp. duty cycle) the model CPV can also be re-classified up to 3 m/M6.
- Main contactor as standard, for increased safety.
- Increased operating safety through 42 V control voltage (low voltage control), push-button pendant control, IP 65.
- 2 year warranty (excluding wear parts) and a lifetime lubricated gearbox.
- Duty cycle 50% ED for single speed.
- Electromagnetic spring pressure brake holds the load safely even in the event of power failure.
- Standard operating voltage:
Euro-voltage 400 V, 3-phase, 50 Hz, alternatively 460 V, 3-phase, 60 Hz. Single speed motors reconnectable to 230 V, 3-phase, 50 Hz.
- Motor protected to IP 55 (acc. to VDE 0530), against ingress of dust and water jets.
- The externally adjustable slip clutch is designed to guarantee a permanent connection between the load and the brake.
- The standard, oil bath lubricated and case hardened gearbox has a helical gearing for particularly smooth running and enhanced lifetime.
- Suspension lug for compact dimensions and easy integration in closed-eye constructions.
- Chain guide made of fibre coated polyamide for increased wear resistance.

High speed units up to 20 m/min available

Also available as 230 V, 1-phase, 50 Hz (25% ED) version.

Optionally available with electric trolley.

Options

- Stainless steel load chain (no reduction of working load limit).
- Suspension hook
- Flexible chain container.
- Other operating voltages.
- Counter for operating hours and number of starts.
- Radio remote control
- Control for synchronized operation of several hoists.
- Manual and electric trolleys.
- Connection to festooned cable systems.
- Suspension for light crane systems.



Find out more about this product or get a quotation

DLHONLINE

Technical data model CPV/CPVF

Model	EAN-No. 4025092*	Capacity in kg/ number of chain falls	Chain dimensions d x p mm	Classification FEM/ISO	Lifting speed**** main lift m/min	Lifting speed fine lift m/min	Hoist motor kW	Motor rating ED %	Weight* suspension lug kg	Weight* push trolley** kg	Weight* electric trolley*** kg
CPV 2-8	*173070	250/1	4x12.2	1Am/M4	8	-	0.37	50	24	39	47
CPVF 2-8	*173063	250/1	4x12.2	1Am/M4	8	2	0.37/0.09	33/17	25	40	48
CPV 2-20	*303705	250/1	5x15.1	1Am/M4	20	-	0.75	50	26	41	49
CPVF 2-20	*925341	250/1	5x15.1	1Am/M4	20	5	0.75/0.18	33/17	27	42	50
CPV 5-4	*174466	500/2	4x12.2	1Am/M4	4	-	0.37	50	25	40	48
CPVF 5-4	*174442	500/2	4x12.2	1Am/M4	4	1	0.37/0.09	33/17	26	41	49
CPV 5-8	*173766	500/1	5x15.1	1Am/M4	8	-	0.75	50	26	41	49
CPVF 5-8	*173803	500/1	5x15.1	1Am/M4	8	2	0.75/0.18	33/17	27	42	50
CPV 5-20	*303712	500/1	7.1x20.5	1Am/M4	20	-	1.5	50	58	77	84
CPVF 5-20	*303729	500/1	7.1x20.5	1Am/M4	20	5	1.5/0.37	33/17	59	78	85
CPV 6-16	*365123	630/1	7.1x20.5	1Am/M4	16	-	1.5	50	58	77	84
CPVF 6-16	*948548	630/1	7.1x20.5	1Am/M4	16	4	1.5/0.37	33/17	59	78	85
CPV 10-4	*174473	1000/2	5x15.1	1Am/M4	4	-	0.75	50	28	43	51
CPVF10-4	*174725	1000/2	5x15.1	1Am/M4	4	1	0.75/0.18	33/17	29	44	52
CPV 10-8	*173797	1000/1	7.1x20.5	1Am/M4	8	-	1.5	50	58	77	84
CPVF10-8	*173780	1000/1	7.1x20.5	1Am/M4	8	2	1.5/0.37	33/17	59	78	85
CPV 20-4	*174480	2000/2	7.1x20.5	1Am/M4	4	-	1.5	50	63	82	89
CPVF 20-4	*174459	2000/2	7.1x20.5	1Am/M4	4	1	1.5/0.37	33/17	64	83	90

*Weight at standard lift (3m). Other lifting heights on request.
 **For trolleys type A and B: Additional weight for geared trolley (VTG): 2.5 kg
 ***For electric trolley (VTE) with 2 speeds +2.0 kg
 ****Lifting speed CPV 10-8 at 230V, 1-phase, 50 Hz = 4 m/min - Lifting speed CPV 20-4 at 230V, 1-phase, 50 Hz = 2 m/min

Yale hoists and trolleys are not designed for passenger elevation applications and must not be used for this purpose.



Increased operating safety through 42V control voltage



Externally adjustable slip clutch.



Integrated limit switch



Depicted suspension hook and chain container optionally available.

Encapsulated pendant control. Option: radio remote control (in combination with integrated trolley).

Find out more about this product or get a quotation

Technical data trolleys

Suitable for	Capacity kg	Size	Beam flange width b mm	Beam flange thickness t max. mm	Curve radius min. m	Electric trolley travel speed m/min at 50 Hz	Electric trolley motor kW at 50 Hz
from CPV 2-8 up to CPVF 10-4	1000	A	58 - 180	19	0.9	18 or 18/4.5	0.18 or 0.18/0.06
from CPV 2-8 up to CPVF 10-4	1000	B	180 - 300	19	0.9	18 or 18/4.5	0.18 or 0.18/0.06
from CPV 6-16 up to CPVF 20-4	2000	A	58 - 180	19	1.15	18 or 18/4.5	0.18 or 0.18/0.06
from CPV 6-16 up to CPVF 20-4	2000	B	180 - 300	19	1.15	18 or 18/4.5	0.18 or 0.18/0.06
CPV/CPVF 5-20	2000	A	58 - 180	19	1.15	18 or 18/4.5	0.18 or 0.18/0.06
CPV/CPVF 5-20	2000	B	180 - 300	19	1.15	18 or 18/4.5	0.18 or 0.18/0.06

Dimensions model CPV/CPVF

Model	CPV/CPVF 2-8	CPV/CPVF 5-4	CPV/CPVF 5-8 CPV/CPVF 2-20	CPV/CPVF 10-4	CPV/CPVF 10-8 CPV/CPVF 5-20 CPV/CPVF 6-16	CPV/CPVF 20-4
A, mm	357	393	357	430	431	528
A1, mm	196	196	196	196	234	234
A2 (Size I), mm	476	476	476	476	564	564
A2 (Size II), mm	526	526	526	526	644	644
A2 (Size III), mm	606	606	606	606	734	734
A2 (Size IV), mm	798	798	798	798	934	934
B, mm	22	22	22	29	29	37
B1, mm	15	15	15	15	20	20
C, mm	29	29	29	35	35	40
C1, mm	38	38	38	38	45	45
C2, mm	105	105	105	105	154	154
D, mm	15	15	15	21	21	26
D1, mm	15	15	15	15	15	15
E, mm	277	277	277	277	326	326
G, mm	120	144	120	144	140	173
G1 (Size I), mm	142	166	142	166	175	208
G1 (Size II), mm	162	186	162	186	175	208
G1 (Size III), mm	162	186	162	186	175	208
G1 (Size IV), mm	162	186	162	186	175	208
H, mm	157	133	157	133	186	154
H2, mm	158	158	158	158	186	186
K (CPV), mm	208	208	208	208	285	285
K (CPVF), mm	208	208	208	208	285	285
M (Size I), mm	162	162	162	162	209	209
M (Size II), mm	197	197	197	197	209	209
M (Size III), mm	197	197	197	197	209	209
M (Size IV), mm	197	197	197	197	209	209
N*, mm	219	219	219	219	274	274

*for 230V, 1-phase, 50 Hz: +35mm

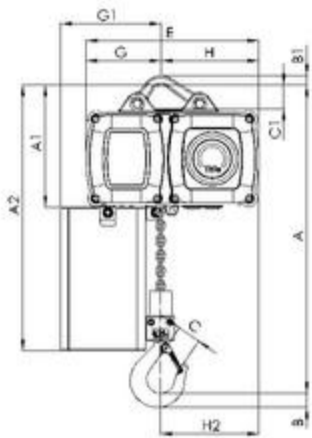

Model CPV/CPVF
with suspension lug, 250 - 1000 kg, single fall

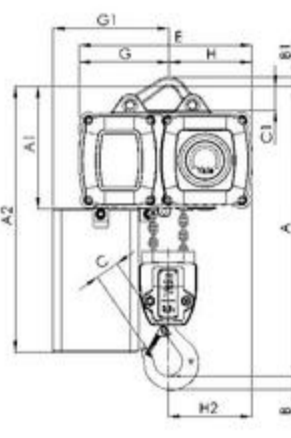
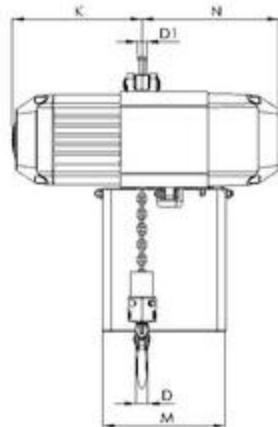

Model CPV/CPVF
with suspension lug, 500 - 2000 kg, double fall

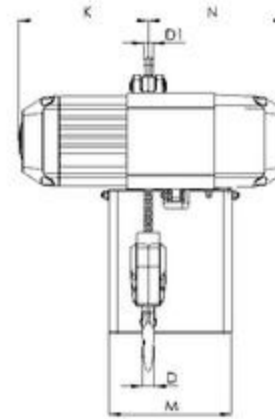

Model CPV/CPVF
with suspension hook,
250 - 2000 kg

Find out more about this product or get a quotation

DLHONLINE

Dimensions model CPV/CPVF

Model	CPV/CPVF 2-8	CPV/CPVF 5-4	CPV/CPVF 5-8 CPV/CPVF 2-20	CPV/CPVF 10-4	CPV/CPVF 10-8 CPV/CPVF 5-20 CPV/CPVF 6-16	CPV/CPVF 20-4
A3, mm	228	228	228	228	263	263
A4 (Size I), mm	508	508	508	508	593	593
A4 (Size II), mm	558	558	558	558	673	673
A4 (Size III), mm	638	638	638	638	768	768
A4 (Size IV), mm	830	830	830	830	968	968
A5, mm	389	425	389	462	460	558
b, mm	A = 58 - 180/ B = 180 - 300	A = 58 - 180/ B = 180 - 300	A = 58 - 180/ B = 180 - 300	A = 58 - 180/ B = 180 - 300	A = 58 - 180/ B = 180 - 300	A = 58 - 180/ B = 180 - 300
H1, mm	24	24	24	24	23	23
H3, mm	129	129	129	129	129	129
H4 (VTG), mm	95	95	95	95	95	95
H4 (VTE), mm	142	142	142	142	142	142
l (Pushed trolley), mm	72	72	72	72	96	96
l (Geared trolley), mm	77	77	77	77	98	98
L (VTP/VTG), mm	310	310	310	310	360	360
L1, mm	130	130	130	130	150	150
L2 (CPV), mm	255	255	255	255	255	255
L2 (CPVF), mm	263	263	263	263	263	263
L3, mm	155	155	155	155	180	180
L4, mm	136	161	173	161	203	203
O, mm	60	60	60	60	80	80
P, mm	180	180	180	180	180	180
P1, mm	246	246	246	246	246	246
S, mm	b + 50	b + 50	b + 50	b + 50	b + 54	b + 54
T, mm	94	94	94	94	94	94
tmax., mm	19	19	19	19	19	19

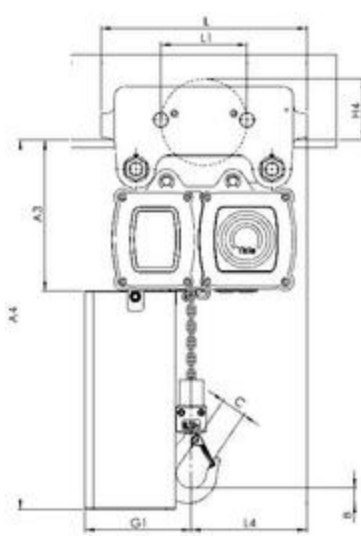

Model CPV/CPVF
with integrated manual push or geared trolley

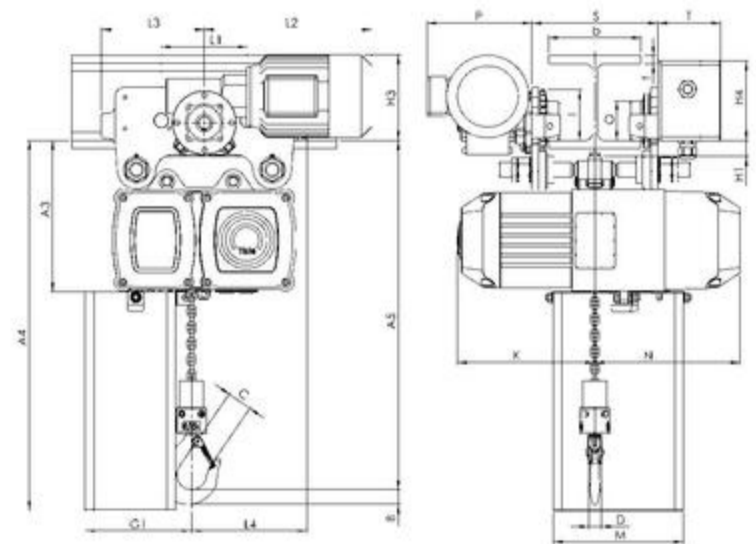
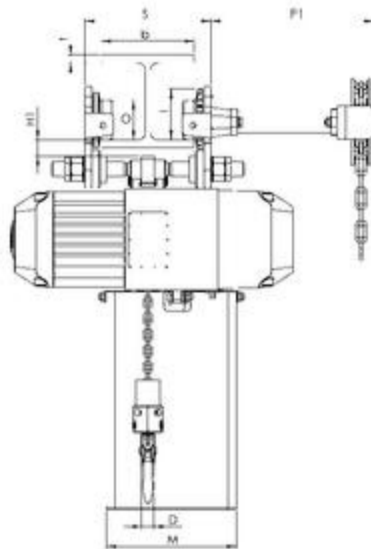

Model CPV/CPVF
with integrated electric trolley

Find out more about this product or get a quotation

DLHONLINE



Electric chain hoist model CPE with suspension hook or with integrated trolley

Capacity 1600 - 10000 kg

The CPE series is a range of high quality products for professional applications. They are highly efficient and engineered for a long working life. The hoists are composed of three main component parts which makes service easy and inexpensive.

Features

- Classification: 1 Am/M4, except models CPE(F) 20-8, CPE(F) 30-5 and CPE(F) 40-4 classification 1 Bm/M3. As required the model CPE (with appropriate changes to lifting capacity resp. duty cycle) can also be re-classified.
 - Direct control or 42 V low voltage control.
 - 2 year warranty (excluding wear parts) as well as a lifetime lubricated gear box.
 - Motor fitted with a bimetallic thermal protection (useable in connection with low voltage control).
 - Duty cycle 40% at one operating speed.
 - The heavy duty squirrel cage motor has an adjustable spring pressure brake that holds the load secure even in the event of a power failure.
 - Standard operating voltage:
Euro-voltage 400 Volt, 3-phase, 50 Hz.
 - Motor protected to IP 54, insulation class F, against ingress of dust and splashing. (acc. to VDE 0530)
 - Encapsulated pendant control protected to IP 65, against ingress of dust and water jets.
 - Up to 3000 kg only one chain fall, leading to a low overall height.
 - The 5-pocket load chain sheave, manufactured from wear resistant case hardening steel, is matched perfectly to the load chain to guarantee smooth and precise chain motion.
 - The standard, oil bath lubricated planetary gearbox is particularly smooth running.
 - Drop forged suspension and load hooks are made from non-aging, high tensile steel and fitted with robust safety latches.
 - The standard case hardened and zinc-plated link chain is matched perfectly to the load chain to guarantee smooth and precise chain motion.
- All requirements of national and international standards and regulations are fulfilled.

Options

- Stainless steel load chain.
- Suspension hook rotated 90°.
- Flexible chain container.
- Other operating voltages.
- Limit switches for highest and lowest hook positions (in combination with low voltage control).
- Motor with stainless steel brake.
- Radio remote control
- Control for synchronized operation of several hoists.
- Manual and electric trolleys.
- Integrated low headroom trolley.
- Connection to festooned cable systems.



**Find out more about this
product or get a quotation**

DLHONLINE

Twin hoist model CPE 100-2

Capacity 10000 kg

The model CPE 100-2 consists of two CPE 50-2 units.

They are connected by a framework.

Hook suspension, geared or electric trolleys are available.

Integrated limit switches for highest and lowest hook positions are standard.

42V low voltage control as standard.

Options

- Stainless steel load chain.
- Flexible chain container
- Other operating voltages
- Motor with stainless steel brake.
- Radio remote control
- Festooned cable system



Find out more about this product or get a quotation



5-pocket load chain sheave machined for smooth, precise chain motion.



Universal connection to suspension hook, trolley or steel structures.



Double fall bottom block for capacities between 3200 up to 5000 kg.



Hoist connected directly to trolley with electric drive. Manual pull and geared trolleys also available.



Option: Flexible chain container made from wear resistant textile fabric.

The units are certified by the employer's liability insurance association (Berufsgenossenschaft) and fulfil the requirements of the machinery directive 2006/42/EG.

DLHONLINE



Compact planetary gearbox

Zinc-plated Yale load chain

Push-button pendant control, IP 65

Electric chain hoist with low headroom integrated trolley

Contact us for quotation on 0161 223 1990

! Yale hoists and trolleys are not designed for passenger elevation applications and must not be used for this purpose.

! All capacities and speeds of the standard model CPE are also available for the CPE LH version.

DLHONLINE

Technical data model CPE/CPEF

Model	EAN-No. 4025092*	Capacity in kg/ number of chain falls	Chain dimensions d x p mm	Classification FEM/ISO	Lifting speed main lift m/min	Lifting speed fine lift m/min	Hoist motor kW	Motor rating ED %
CPE 16-8	*073240	1600/1	11x31	1Am/M4	8	-	2.3	40
CPEF 16-8	*073257	1600/1	11x31	1Am/M4	8	2	2.3/0.58	40/20
CPE 20-8	*073264	2000/1	11x31	1Bm/M3	8	-	2.8	25
CPEF 20-8	*073271	2000/1	11x31	1Bm/M3	8	2	2.8/0.7	25/15
CPE 25-5	*073288	2500/1	11x31	1Am/M4	5	-	2.3	40
CPEF 25-5	*073295	2500/1	11x31	1Am/M4	5	1.25	2.3/0.58	40/20
CPE 30-5	*073301	3000/1	11x31	1Bm/M3	5	-	2.8	25
CPEF 30-5	*073318	3000/1	11x31	1Bm/M3	5	1.25	2.8/0.7	25/15
CPE 32-4	*073325	3200/2	11x31	1Am/M4	4	-	2.3	40
CPEF 32-4	*073332	3200/2	11x31	1Am/M4	4	1	2.3/0.58	40/20
CPE 40-4	*073349	4000/2	11x31	1Bm/M3	4	-	2.8	25
CPEF 40-4	*073356	4000/2	11x31	1Bm/M3	4	1	2.8/0.7	25/15
CPE 50-2	*073363	5000/2	11x31	1Am/M4	2.5	-	2.3	40
CPEF 50-2	*073370	5000/2	11x31	1Am/M4	2.5	0.6	2.3/0.58	40/20
CPE 75-1,6	*079907	7500/3	11x31	1Am/M4	1.6	-	2.8	40
CPEF 75-1,6	*079914	7500/3	11x31	1Am/M4	1.6	0.4	2.8/0.58	40/20
CPE 100-2	*060585	10000/4	11x31	1Am/M4	2.5	-	2x2.3	40
CPEF 100-2	*060592	10000/4	11x31	1Am/M4	2.5	0.6	2x2.3/0.58	40/20

Model	Weight* suspension hook kg	Weight* push trolley kg	Weight* geared trolley kg	Weight* electric trolley** kg
CPE 16-8	88	150	154	164
CPEF 16-8	93	155	159	169
CPE 20-8	88	150	154	164
CPEF 20-8	93	155	159	169
CPE 25-5	88	150	154	164
CPEF 25-5	93	155	159	169
CPE 30-5	88	150	154	164
CPEF 30-5	93	155	159	169
CPE 32-4	107	169	173	182
CPEF 32-4	112	174	178	187
CPE 40-4	107	169	173	182
CPEF 40-4	112	174	178	187
CPE 50-2	107	169	173	182
CPEF 50-2	112	174	178	187
CPE 75-1,6	220	320	320	340
CPEF 75-1,6***	226	326	326	346
CPE 100-2	282	-	385	406
CPEF 100-2***	287	-	390	411

* Weight at standard lift (3 m). Other lifting heights on request.
 ** Additional weight for 2 speed version 2.0 kg
 *** Limit switches for highest and lowest hook positions – 42V low voltage control.

Find out more about this product or get a quotation

**For low headroom
 Contact us for quotation
 on 0161 223 1990**



Technical data trolleys

Capacity kg	Size	Beam flange width b mm	Beam flange thickness t max. mm	Curve radius min. m	Electric trolley travel speed m/min at 50Hz	Electric trolley motor kW at 50Hz
1600 - 5000	A	98 - 180	27	2.0	11 or 11/2.8	0.37 or 0.3/0.09
1600 - 5000	B	180 - 300	27	1.8	11 or 11/2.8	0.37 or 0.3/0.09
7500 - 10000	B	125 - 310	40	1.8	5 or 5/1.25	0.55 or 0.55/0.12

Dimensions model CPE/CPEF

Model	CPE/CPEF 16-8	CPE/CPEF 20-8	CPE/CPEF 25-5	CPE/CPEF 30-5	CPE/CPEF 32-4	CPE/CPEF 40-4	CPE/CPEF 50-2	CPE/CPEF 75-1,6	CPE/CPEF 100-2
A, mm	516	516	516	516	681	681	681	950	1068
A1, mm	286	286	286	286	428	428	428	479	651
A2 (13m), mm	430	430	430	430	430	430	430	-	-
A2 (21m), mm	530	530	530	530	530	530	530	530	555
B, mm	35	35	35	35	45	45	45	60	60
C, mm	37	37	37	37	46	46	46	52	52
D, mm	24	24	24	24	30	30	30	40/45	40/45
E, mm	24	24	24	24	24	24	24	-	-
F1, mm	160	160	160	160	160	160	160	160	160
F2, mm	178	178	178	178	178	178	178	178	178
G, mm	220	220	220	220	220	220	220	220	-
G1, mm	180	180	180	180	140	140	140	268	315
G2 (13m), mm	257	257	257	257	218	218	218	-	-
G2 (21m), mm	277	277	277	277	238	238	238	345	408
H1, mm	110	110	110	110	110	110	110	110	135
H2, mm	135	135	135	135	135	135	135	307	256
K1, mm	100	100	100	100	100	100	100	92	92
K2, mm	51	51	51	51	51	51	51	62	62
M, mm	50	50	50	50	10	10	10	138	-
N, mm	84	84	84	84	124	124	124	136	390
Q1, mm	280	280	280	280	280	280	280	280	280
Q2 (CPE), mm	362	362	362	362	362	362	362	362	362
Q2 (CPEF), mm	417	417	417	417	417	417	417	417	417

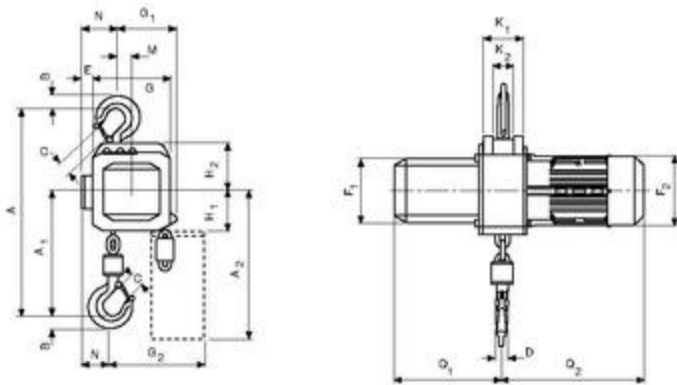

Model CPE/CPEF with suspension hook, 1600 - 3000 kg, single fall

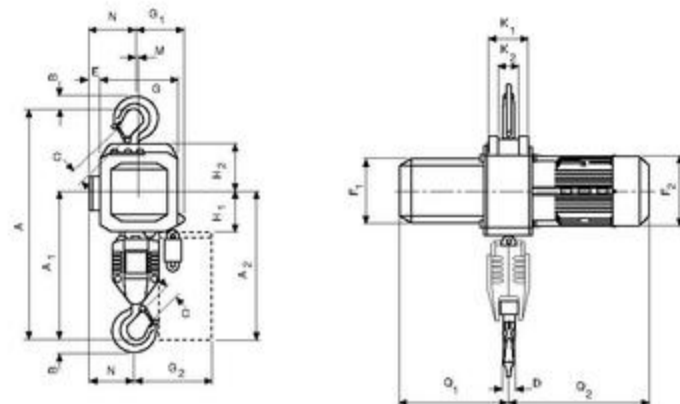

Model CPE/CPEF with suspension hook, 3200 - 5000 kg, double fall

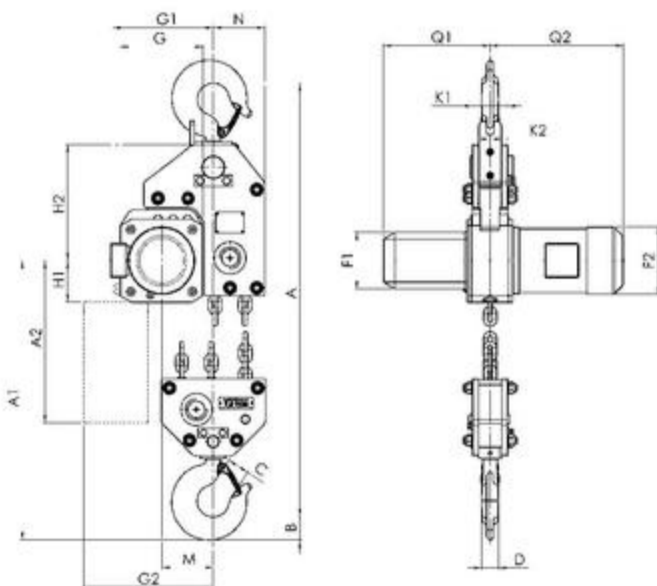

Model CPE/CPEF 75-1,6 with suspension hook, 7500 kg

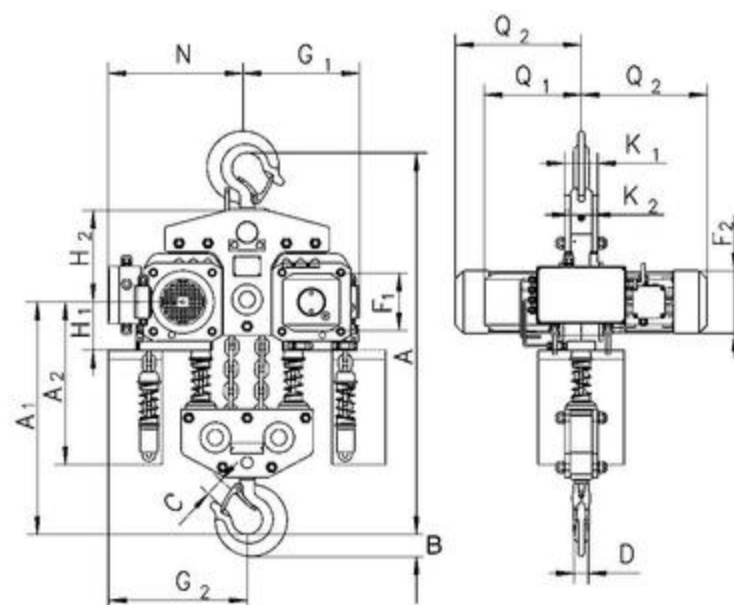

Model CPE/CPEF 100-2 with suspension hook, 10000 kg

DLHONLINE

Dimensions model CPE/CPEF

Model	CPE/CPEF 16-8	CPE/CPEF 20-8	CPE/CPEF 25-5	CPE/CPEF 30-5	CPE/CPEF 32-4	CPE/CPEF 40-4	CPE/CPEF 50-2	CPE/CPEF 75-1,6	CPE/CPEF 100-2
A3, mm	121	121	121	121	121	121	121	-	110
A4, mm	465	465	465	465	615	615	615	855	965
A5, mm	298	298	298	298	298	298	298	477	450
A6, mm	178	178	178	178	178	178	178	-	170
b, mm	A = 98 - 180/ B = 180 - 300	A = 98 - 180/ B = 180 - 300	A = 98 - 180/ B = 180 - 300	A = 98 - 180/ B = 180 - 300	A = 98 - 180/ B = 180 - 300	A = 98 - 180/ B = 180 - 300	A = 98 - 180/ B = 180 - 300	125 - 310	125 - 310
F, mm	150	150	150	150	150	150	150	113	113
l, mm	142.5	142.5	142.5	142.5	142.5	142.5	142.5	170	170
L1, mm	209	209	209	209	209	209	209	200	200
L2, mm	262.5	262.5	262.5	262.5	262.5	262.5	262.5	215	215
L3 (VTE), mm	292	292	292	292	292	292	292	-	335
L3 (VTEF), mm	296	296	296	296	296	296	296	-	335
L4, mm	213	213	213	213	253	253	253	215	390
L5, mm	312	312	312	312	272	272	272	215	215
L6 (VTE), mm	342	342	342	342	342	342	342	-	-
L6 (VTEF), mm	346	346	346	346	306	306	306	-	-
O, mm	125	125	125	125	125	125	125	150	150
P (VTE), mm	197	197	197	197	197	197	197	-	273
P (VTEF), mm	205	205	205	205	205	205	205	-	280
P1, mm	229	229	229	229	229	229	229	-	110
S, mm	b + 70	b + 70	b + 70	b + 70	b + 70	b + 70	b + 70	b + 98	b + 98
T, mm	94	94	94	94	94	94	94	-	94
tmax., mm	27	27	27	27	27	27	27	40	40

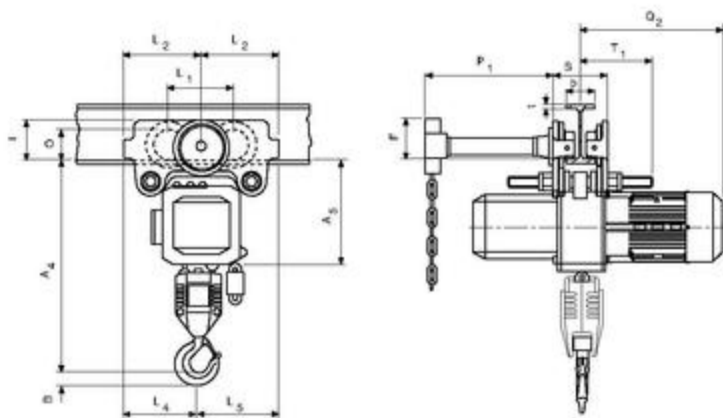

Model CPE/CPEF with integrated manual push or geared trolley

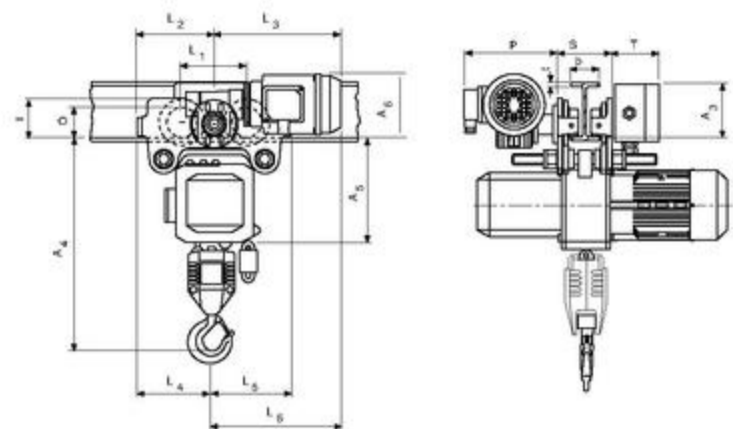

Model CPE/CPEF with integrated electric trolley

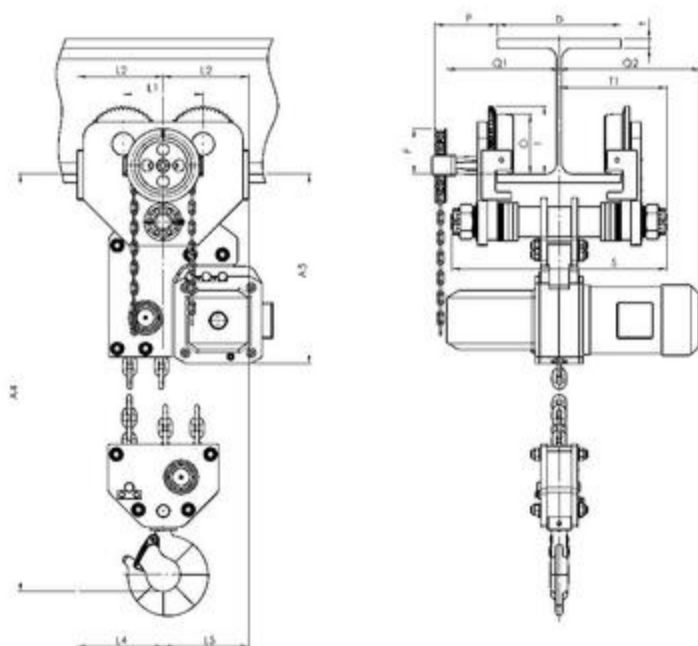

Model CPE/CPEF with integrated geared or electric trolley, 7500 kg

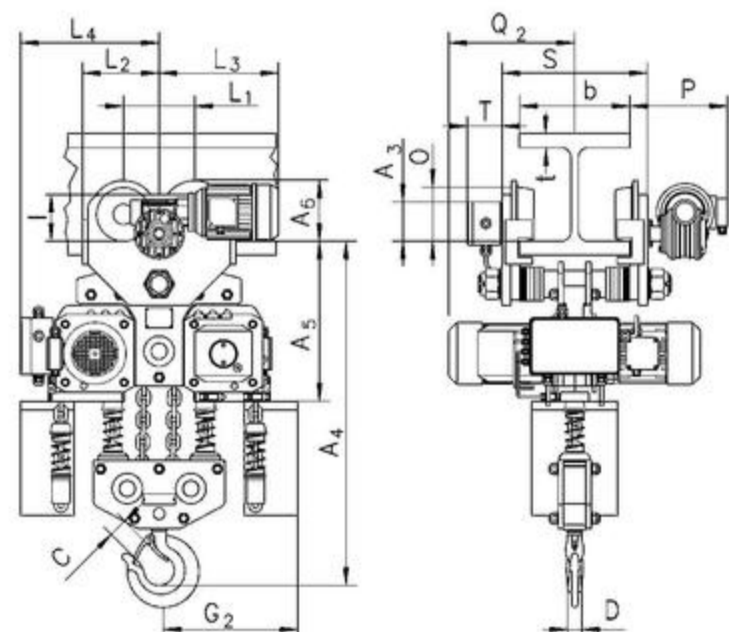

Model CPE/CPEF with integrated electric trolley, 10000 kg

DLHONLINE

Pneumatic chain hoist model CPA

Capacity 125 - 980 kg

Pneumatic chain hoists are characterized by high durability in a great number of industrial applications. The robust but light weight housing allows an easy transport.

Features

- Designed for operating pressures of 5 to 7 bar.
- Rotating piston motor with 100% duty rating and an unlimited number of starts for continuous operation.
- Integrated limit switches for highest and lowest hook position as standard.
- Self-adjusting automatic disc brake, maintenance-free.
- Extremely sensitive control with emergency-stop for a precise positioning of the load
- Air release for brake as standard for models CPA 2-31, CPA 5-17 and CPA 10-9

Options

- Manual and powered trolleys with shackle to fit top hook suspended pneumatic chain hoists.
- All models available with push or geared trolley
- Models CPA 2-31, CPA 5-17 and CPA 10-9 also available with pneumatic trolleys
- Models CPA 2-31, CPA 5-17 and CPA 10-9 also available for operation in hazardous areas, category 2 (Zone 1/21)
- Models CPA 2-31, CPA 5-17 and CPA 10-9 also available with chain control
- Maintenance unit for main air supply pipe (pressure regulator, manometer, lubricator and support)
- Chain container

Applications

Automobile and aircraft industries, shipyards, on ships and docks. Foundries, on-/offshore, paint factories and paint shops, refineries, oil depots, galvanizing. Printing, textile and food industries, pulp, paper and cement mills. Glass and ceramic industries, wood working industries, chemical industries, heat treatment and power plants etc.



Depicted chain container optionally available.



Available in explosion proof version.

! Also suitable for operation with nitrogen.

! To ensure faultless operation the compressed air supply must be filtered and oiled.

DLHONLINE

Technical data model CPA

Model	EAN-No. 4025092*	Capacity in kg/ number of chain falls	Lifting speed with rated load* m/min	Lifting speed without load* m/min	Lowering speed with rated load* m/min	Air consumption with rated load* m ³ /min	Hoist motor kW	Weight at standard lift (3 m) kg
CPA 1-13	*911795	125/1	13.1	17.1	11.3	0.9	0.4	15.4
CPA 2-10	*911788	250/1	9.8	17.1	13.7	0.9	0.4	15.4
CPA 2-31	*911801	250/1	31.0	52.0	36.0	1.98	1.33	21.8
CPA 5-5	*911818	500/2	4.6	7.9	6.7	0.9	0.4	17.2
CPA 5-17	*911825	500/1	16.8	32.3	29.6	1.27	1.33	21.8
CPA 10-9	*911832	980/2	8.5	16.2	14.9	1.27	1.33	27.7

*Values for 6.3 bar (flow pressure) and 2 m control drop. Speeds will be reduced in case of longer control length. Hose length max. 12 m. Model CPA 1-13, CPA 2-10 and CPA 5-5 hose length max. 12 m, CPA 2-31, CPA 5-17 and CPA 10-9 hose length max. 20 m.

Dimensions model CPA

Model	CPA 1-13	CPA 2-10	CPA 2-31	CPA 5-5	CPA 5-17	CPA 10-9
A, mm	292	292	457	324	457	457
A1, mm	410	410	483	410	483	508
B, mm	21	21	25	14	25	27
C, mm	20	20	24	24	24	28
D, mm	16	16	26	14	26	28
F1, mm	90	90	130	90	130	130
F2, mm	120	120	180	120	180	180
K, mm	103	103	146	103	146	165
L, mm	57	57	102	57	102	83
M, mm	120	120	114	120	114	135
N, mm	50	50	54	50	54	25
Q1, mm	142	142	162	142	162	162
Q2, mm	183	183	181	183	181	181

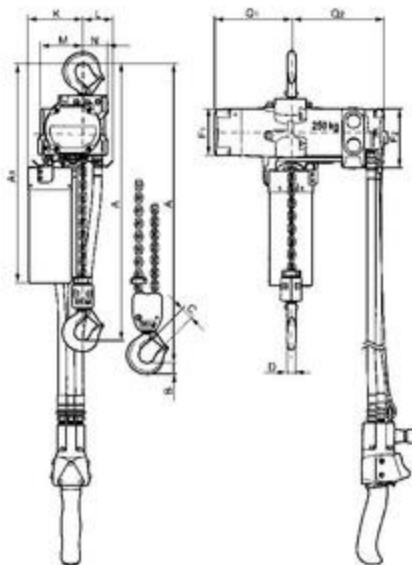

Model CPA 1-13 / 2-10 / 5-5

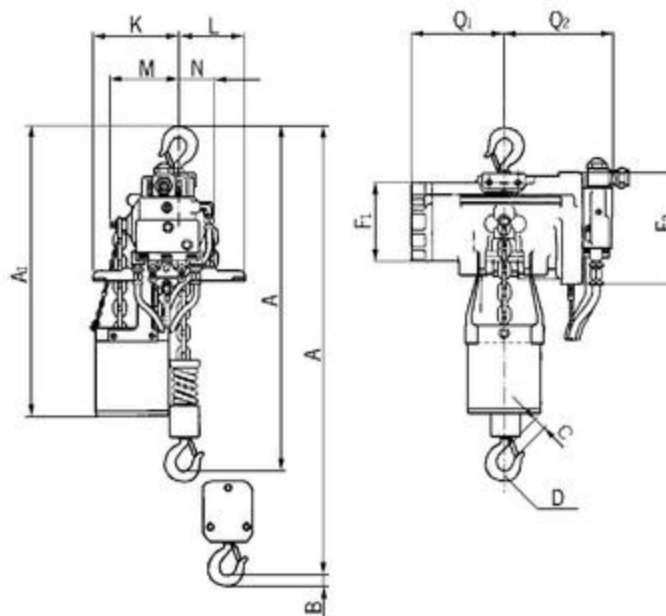

Model CPA 2-31 / 5-17 / 10-9

DLHONLINE



Find out more about this product or get a quotation

To ensure faultless operation the compressed air supply must be filtered and oiled.

**Pneumatic chain hoist
model CPA
with suspension hook or with
integrated trolley**

Capacity 2000 - 10000 kg

The conception is in accordance with the design of the model CPE.

With 100% duty rating and an unlimited number of starts the model CPA is suitable for heavy duty applications. It is insusceptible to contamination, humidity and aggressive mediums from the outside. The hoists are composed of three main components which makes service easy and inexpensive.

Features

- Designed for operating pressures of 4 to 6 bar.
 - Robust rotating piston motor has an adjustable spring pressure brake that holds the load secure even in the event of an air failure.
 - The standard, oil bath lubricated planetary gearbox is particularly smooth running and enables a low overall height.
 - High starting torque due to switching valves in the motor body.
 - Low noise emission due to large dimension silencer.
 - Sensitive control by means of 2 resp. 4 button pendant control with emergency-stop.
 - Up to 3000 kg only one chain fall, leading to a low overall height.
 - The 5-pocket load chain sheave, manufactured from wear resistant case hardening steel, is matched perfectly to the load chain to guarantee smooth and precise chain motion.
 - Drop forged suspension and load hooks are made from non-aging, high tensile steel and fitted with robust safety latches.
 - The standard case hardened and zinc-plated link chain is matched perfectly to the load chain to guarantee smooth and precise chain motion.
- All requirements of national and international standards and regulations are fulfilled.

Options

- Manual and pneumatic trolleys.
- Rope control
- Stainless steel load chain.

DLHONLINE

Technical data model CPA

Model	EAN-No. 4025092*	Capacity in kg/ number of chain falls	Lifting speed with rated load* m/min	Lifting speed without load* m/min	Lowering speed with rated load* m/min	Hoist motor kW	Weight** suspension hook kg	Weight** push trolley kg	Weight** geared trolley kg	Weight** pneumatic trolley kg
CPA 20-8	*073868	2000/1	7.4	9.9	11.0	2.6	121	184	188	199
CPA 30-6	*073875	3000/1	6.0	9.9	13.0	3.2	121	184	188	199
CPA 40-4	*073882	4000/2	3.7	5.0	5.5	2.6	140	202	206	218
CPA 50-3	*073899	5000/2	3.4	5.0	6.0	3.0	140	202	206	218
CPA 60-3	*073905	6000/2	3.0	5.0	6.5	3.2	140	202	206	218
CPA 75-2	*056915	7500/3	2.0	3.3	4.3	3.2	-	-	-	-
CPA 100-3	*075701	10000/4	3.4	5.0	6.0	2x3.0	-	-	-	-

*Values for 6 bar (flow pressure), air consumption with rated load 4.7 m³/min. CPA 100-3: 9.4 m³/min.
 **Weight at standard lift (3 m). Other lifting heights on request.

Find out more about this product or get a quotation



Application with pneumatic trolley



Available in explosion proof version.

Technical data trolleys

Capacity kg	Size	Beam flange width b mm	Beam flange thickness t max. mm	Curve radius min. m	Pneumatic trolley travel speed m/min	Pneumatic trolley motor kW
2000 - 6000	A	98 - 180	27	2.0	18	0.55
2000 - 6000	B	180 - 300	27	1.8	18	0.55
7500 - 10000	B	125 - 310	40	1.8	-	-

! Other capacities on request.

Dimensions model CPA

Model	CPA 20-8	CPA 30-6	CPA 40-4	CPA 50-3	CPA 60-3	CPA 75-2	CPA 100-3
A, mm	516	516	681	681	681	950	1068
A1, mm	286	286	428	428	428	479	651
B, mm	35	35	45	45	47	60	60
C, mm	37	37	46	46	42	52	52
D, mm	24	24	30	30	30	40/45	40/45
F1, mm	160	160	160	160	160	160	160
F2, mm	165	165	165	165	165	165	165
G, mm	220	220	220	220	220	220	581
G1, mm	180	180	140	140	140	268	311
G2 (13 m), mm	258	258	218	218	218	-	-
G2 (21 m), mm	278	278	238	238	238	345	408
H1, mm	110	110	110	110	110	110	110
H2, mm	135	135	135	135	135	307	256
H3, mm	115	115	115	115	115	115	115
K1, mm	100	100	100	100	100	92	92
K2, mm	51	51	51	51	51	62	62
M, mm	50	50	9.6	9.6	9.6	139	181
N, mm	60	60	100	100	100	136	291
Q1, mm	272	272	272	272	272	272	272
Q2, mm	325	325	325	325	325	325	325

Find out more about this product or get a quotation

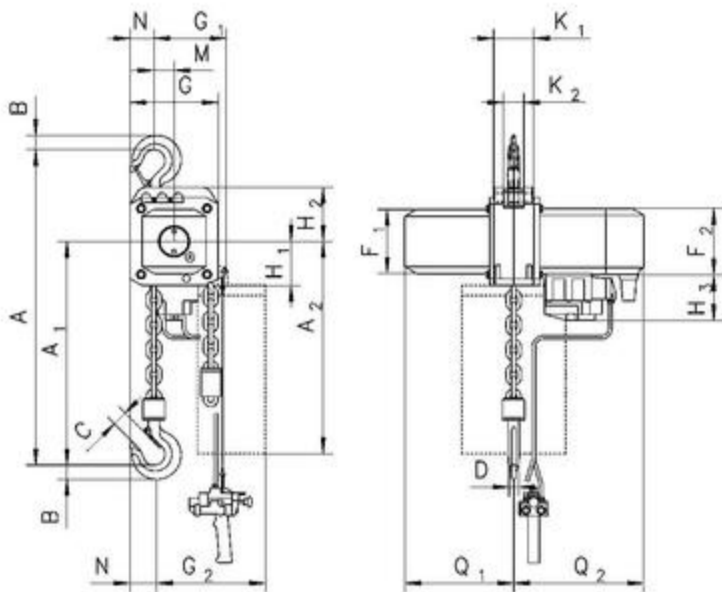

Model CPA with suspension hook, 2000 - 3000 kg, single fall

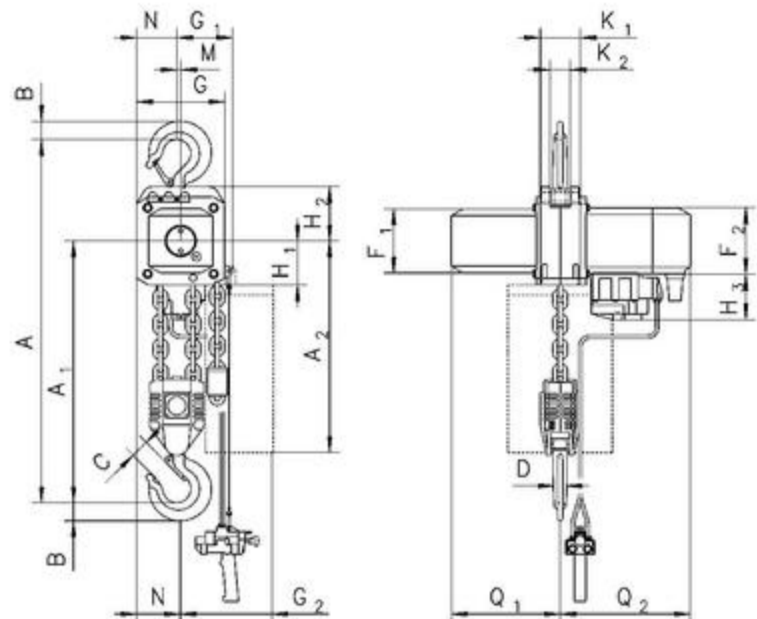

Model CPA with suspension hook, 4000 - 6000 kg, double fall

DLHONLINE

Dimensions model CPA

Model	CPA 20-8	CPA 30-6	CPA 40-4	CPA 50-3	CPA 60-3	CPA 75-2	CPA 100-3
A2 (13 m), mm	430	430	430	430	430	-	-
A2 (21 m), mm	530	530	530	530	530	530	530
A4, mm	465	465	615	615	615	855	965
A5, mm	298	298	298	298	298	477	425
A6, mm	190	190	190	190	190	182	182
b, mm	A = 98 - 180/ B = 180 - 300	A = 98 - 180/ B = 180 - 300	A = 98 - 180/ B = 180 - 300	A = 98 - 180/ B = 180 - 300	A = 98 - 180/ B = 180 - 300	125 - 310	125 - 310
F, mm	150	150	150	150	150	113	113
l, mm	142.5	142.5	142.5	142.5	142.5	130	130
L1, mm	209	209	209	209	209	200	200
L2, mm	262.5	262.5	262.5	262.5	262.5	215	215
L3, mm	265	265	265	265	265	265	265
L4, mm	213	213	253	253	253	291	291
L5, mm	312	312	272	272	272	-	-
L6, mm	315	315	275	275	275	-	-
O, mm	125	125	125	125	125	150	150
P, mm	208	208	208	208	208	208	208
P1, mm	284	284	284	284	284	284	284
S, mm	b + 70	b + 70	b + 70	b + 70	b + 70	b + 98	b + 98
t, mm	27	27	27	27	27	40	40
T1 size A	182	182	182	182	182	-	-
T1 size B	242	242	242	242	242	270	270

Find out more about this product or get a quotation

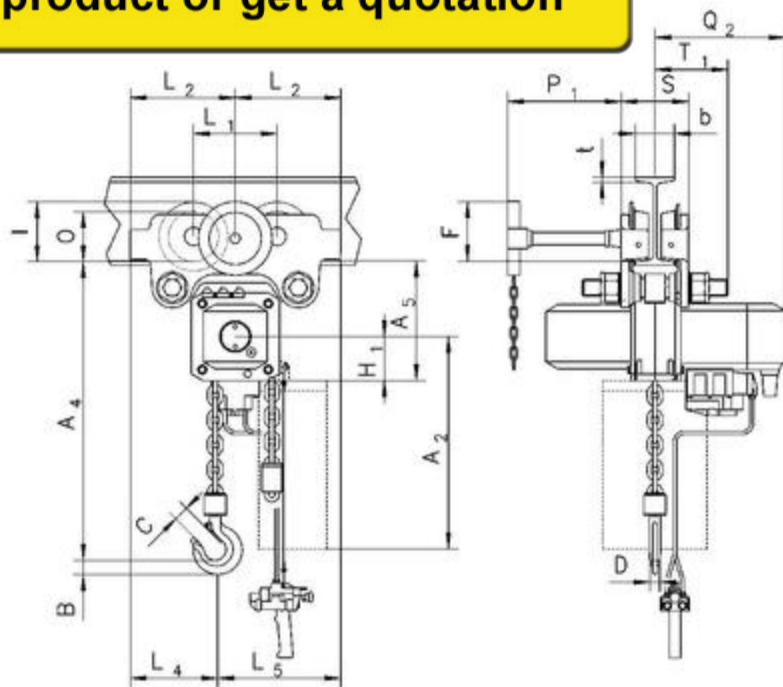

Model CPA with integrated manual push or geared trolley

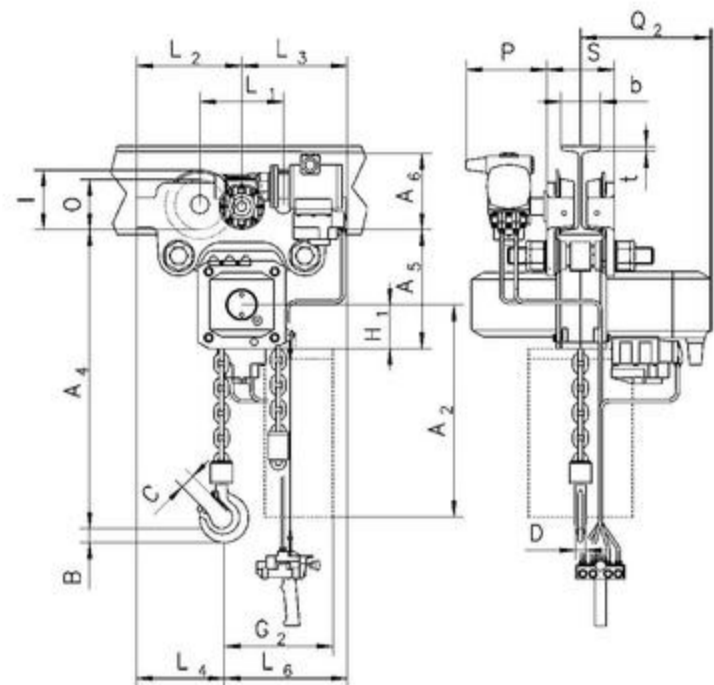

Model CPA with integrated pneumatic trolley

Yale link chains, zinc-plated

for	EAN-No. 4025092*	Capacity in kg/ number of chain falls	Chain dimensions d x p mm	Chain stop
Model D 85	*050920	750/1	6 x 18.5	•
	*050937	1500/1	9 x 27	•
	*050951	3000/1	11 x 31	•
	*050951	6000/2	11 x 31	•
	*050951	10000/3	11 x 31	•
Model D 95	*051002	1500/1	6.2 x 18.5	•
	*051422	3000/1	9 x 27.2	•
Model AL	*051323	750/1	6.3 x 19.1	•
	*051323	1000/1	6.3 x 19.1	•
	*051347	1500/1	7.1 x 21.2	•
Model PT	*051378	3000/1	10 x 30.2	•
	*051415	800/1	5.6 x 17.1	–
	*051347	1600/1	7.1 x 21.2	•
Model UNOplus	*051422	3200/1	9 x 27.2	•
	*051422	6300/2	9 x 27.2	•
	*053846	750/1	6 x 18	•
	*053860	1500/1	8 x 24	•
Model Yalehandy	*053884	3000/1	10 x 30	•
	*053884	6000/2	10 x 30	•
Model Yalelift 360	*051316	250/1	4 x 12	–
	*051316	500/1	4 x 12	–
Model VSIII	*075244	500/1	5 x 15	–
	*053846	1000/1	6 x 18	•
	*053860	1500/1	8 x 24	•
	*053860	2000/1	8 x 24	•
	*053860	2000/2	8 x 24	•
	*053860	3000/2	8 x 24	•
	*053884	3000/1	10 x 30	•
	*053884	5000/2	10 x 30	•
	*077002	10000/3	10 x 30	•
	*077002	20000/6	10 x 30	•
Model CPS	*053846	1000/1	6 x 18	•
	*053860	1500/1	8 x 24	•
Model CPV	*053860	2000/2	8 x 24	•
	*053860	3000/2	8 x 24	•
Model CPE/CPA	*053884	3000/1	10 x 30	•
	*053884	5000/2	10 x 30	•
	*076074	125 - 250/1	4 x 12.2	–
	*076074	500/2	4 x 12.2	–
	*081030	500/1	5 x 15.1	–
	*081030	1000/2	5 x 15.1	–
Model C 85	*081047	1000/1	7.1 x 20.5	•
	*081047	2000/2	7.1 x 20.5	•
	*079389	125 - 250/1	4 x 12	–
	*079396	500 - 990/1	7 x 21	•
	*056489	1600 - 3000/1	11 x 31	•
Model C 85	*056489	3200 - 6000/2	11 x 31	•
	*056489	7500/3	11 x 31	•
	*056489	10000/4	11 x 31	•

Yale roller chains

for	EAN-No. 4025092*	Capacity in kg/ number of chain falls	Chain dimensions d x p inch	Chain stop
Model C 85	*050449	750/1	5/8" x 3/8"	on request
	*050456	1500/1	1" x 1/2"	on request
	*050463	3000/1	1 1/4" x 5/8"	on request
	*050463	6000/2	1 1/4" x 5/8"	on request
	*050463	10000/3	1 1/4" x 5/8"	on request

Yale chain stop for link chains model YKST

Yale chain stops have been developed for Yale hoists with round-section steel chains as an additional protection against falling.

The two available sizes cover two different ranges of chain sizes.

The load capacity indicated on the chain stop is the maximum working load limit (rated load) that must not be exceeded by the respective hoist used.

The chain stop can be moved along the load chain of the hoist by actuating the safety device and pressing the slider at the same time. When the slider is released, it automatically locks in the load chain and the safety lock blocks the system.

In order to ensure safe functioning of the chain stop, the distance between the chain stop and the hoist must not exceed 15 - 20 mm. After the use of the hoist, the chain stop must be repositioned, as required.



Model	Suitable for chain mm	Capacity WLL kg	Dimensions L x W x D mm	Weight kg
YKST 16	5.6 - 8	1600	75 x 56 x 15	0.35
YKST 32	9 - 11	3200	105 x 82 x 24	1.15

! The use for different chain dimensions is not permitted.

Contact us for prices on 0161 223 1990

DLHONLINE

Yale link chains, stainless steel

for	EAN-No. 4025092*	Capacity in kg/ number of chain falls	Capacity max. per chain hoist kg	Chain dimensions d x p mm	Chain stop
Model D 85	*050944	1500/1	1500	9 x 27	•
Model D 95	on request	1500/1	-	6.2 x 18.5	•
Model AL	*051330	750/1	750	6.3 x 19.1	•
	*051330	1000/1	1000	6.3 x 19.1	•
	*051354	1500/1	1250	7.1 x 21.2	•
	*051385	3000/1	2000	10 x 30.2	•
Model PT	*051354	1600/1	1250	7.1 x 21.2	•
Model UNOplus	*053853	750/1	750	6 x 18	•
	*053877	1500/1	1250	8 x 24	•
	*053891	3000/1	2000	10 x 30	•
	*053891	6000/2	4000	10 x 30	•
Model Yalelift 360	*058506	500/1	500	5 x 15	-
	*053853	1000/1	900	6 x 18	•
	*053877	2000/1	1250	8 x 24	•
	*053891	3000/1	2000	10 x 30	•
Model VSIII	*053891	5000/2	4000	10 x 30	•
	*221498	500/1	250	4 x 12	•
	*058506	500/1	500	5 x 15	•
	*053853	1000/1	900	6 x 18	•
	*053877	1500/1	1250	8 x 24	•
	*053853	2000/2	1800	6 x 18	•
	*053877	2000/1	1250	8 x 24	•
	*053877	3000/2	2500	8 x 24	•
Model CPV	*053891	3000/1	2000	10 x 30	•
	*053891	5000/2	4000	10 x 30	•
	*077330	250/1	250	4 x 12.2	-
	*077330	500/2	500	4 x 12.2	-
	*166546	500/1	500	5 x 15.1	-
	*166546	1000/2	1000	5 x 15.1	-
Model CPA	*166553	1000/1	1000	7.1 x 20.5	•
	*166553	2000/2	2000	7.1 x 20.5	•
	*221498	125/1	125	4 x 12	-
Model CPE/CPA	*080415	500/1	500	7 x 21	•
	*056410	1600/2000/1	1600/2000	11 x 31	•
	*056410	2500/3000/1	2000	11 x 31	•
	*056410	3200/4000/2	3200/4000	11 x 31	•
	*056410	5000/6000/2	4000	11 x 31	•
	*056410	7500/3	6000	11 x 31	•
	*056410	10000/4	8000	11 x 31	•

Yale hand chains, zinc-plated

for model	EAN-No. 4025092*	Chain dimensions d x p in mm
HTG, VSIII, CPV, CPE, CPA, Yalelift 360	*053907	5 x 26
VSIII 250	*607148	3 x 12
Connection link for hand chain	*014946	5 x 26

Yale hand chains, stainless steel

for model	EAN-No. 4025092*	Chain dimensions d x p in mm
HTG, VSIII, CPV, CPE, CPA, Yalelift 360	*053914	5 x 26
Connection link for hand chain	*955690	5 x 26

**Contact us for prices
on 0161 223 1990**



DLHONLINE



Console-mounted winch model LB

Capacity 150 - 1200 kg

Originally developed as offroad winch the console-mounted winch model LB is used today for a variety of lifting and pulling applications.

Features

- Light weight robust stamped steel housing.
- Spur gear drive for optimal efficiency and comfortable handling.
- Automatic load pressure brake for safe holding of the load in any position. An unintentional brake release is prevented.
- All parts are zinc-plated for increased corrosion protection, drum with additional special coating.
- Easy and quick mounting to consoles, even under lifting conditions.

Options

- Stainless steel version (mat. 1.4301) for increased corrosion protection.
- Free wheeling device for a quick manual unrolling of the unloaded rope.
- Variable crank with adjustable crank handle.
- Foldable crank with tiltable handle for use in confined spaces.

Find out more about this product or get a quotation



Option: Foldable crank with tiltable handle for use in confined spaces.



Option: Variable crank with adjustable crank handle.

DLHONLINE

Technical data model LB

Model	Art.-No. Zinc-plated version	Art.-No. Free wheeling device	Art.-No. Stainless steel version	Capacity 1 st layer kg	Capacity top layer kg	Rope diameter mm	Useable rope length 1 st layer m	Useable rope length max. m	Lift per crank rotation mm	Required crank effort daN	Weight without rope kg
LB 150 VZ	030239016	-	-	150	75	4*	0.8	11	125	17	4.2
LB 350 VZ	030239015	-	-	350	170	4*	1.8	20	125	25	4.8
LB 650 VZ	040239004	-	-	650	290	6*	1	20	55	22	7.3
LB 900 VZ/ARA	040239006	040239007	-	900	400	7*	0.8	14	58	24	10
LB 1200 VZ/ARA	040239008	040239009	-	1200	430	7**	1	26	45	24	12.1
LB 250 VA	-	-	030239017	250	125	4*	1.8	19.5	125	20	4.8
LB 650 VA	-	-	040239012	650	290	6*	1	20	55	22	7.6
LB 900 VA	-	-	030239013	900	320	7*	1	26	45	24	12.1

*recommended rope: DIN 3060 FE-znk 1770 sZ-spa

**recommended rope: DIN 3069 SE-znk 2160 sZ-spa

Dimensions model LB

Model	LB 150 VZ	LB 350 VZ	LB 650 VZ	LB 900 VZ LB 900 ARA	LB 1200 VZ LB 1200 ARA	LB 250 VA	LB 650 VA	LB 900 VA
Art.-No. Zinc-plated version	030239016	030239015	040239004	040239006	040239008	-	-	-
Art.-No. Free wheeling device	-	-	-	040239007	040239009	-	-	-
Art.-No. Stainless steel version	-	-	-	-	-	030239017	040239012	030239013
A, mm	-	-	232	232	273	-	232	273
B, mm	155	155	192	192	266	155	192	266
C, mm	175	175	210	210	240	175	210	240
Ø D, mm	36	36	63.5	63.5	63.5	36	63.5	63.5
Ø E, mm	100	100	183	183	255	100	183	255
F, mm	-	-	100	100	78	-	100	78
G, mm	75	75	58	58	75	75	58	75
H, mm	-	-	100	100	138	-	100	138
K, mm	159	189	192	192/226*	192/226*	191.5	190	190
L, mm	-	-	25	25	35	-	25	35
M, mm	45	75	38	38	30	75	38	30
N, mm	-	-	-	-	53	-	-	53
O, mm	200	320	250	320	320	320	250	250
P, mm	260	290	293	293/303*	293/303*	292.5	291	291
Q, mm	81	111	95	95	95	111	95	95
R, mm	50	80	50	50	50	80	50	50
S, mm	48	63	55	55	55	65.5	55	55

*Free wheeling device

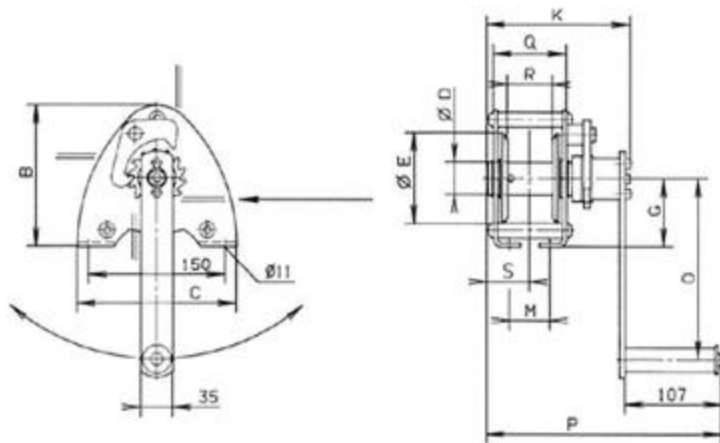

Model LB 150 - 350 kg

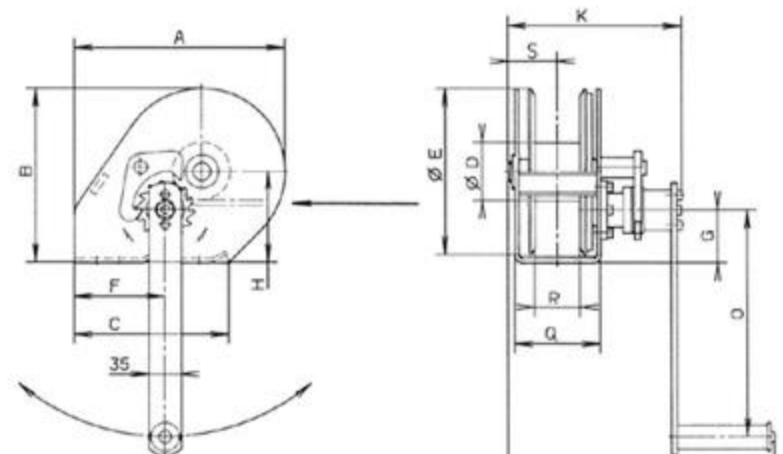

Model LB 650 - 1200 kg

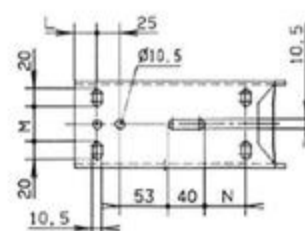

Find out more about this product or get a quotation

DLHONLINE



Wall-mounted winch model SW-W SG

Capacity 80 - 750 kg

Wall-mounted rope winches of the SW-W model range are intended for fixed stationary mounting inside a building. The steel wire rope is guided to the required suspension point of the load by means of deflection sheaves.

Features

- Robust aluminium housing for models SW-W 80 and SW-W 125, proven steel plate design for models SW-W 300 - 750.
- Spur gear drive for optimal efficiency and comfortable handling. Direct drive for loads up to 125 kg.
- The low-noise safety spring brake safely holds the load in every position.
- Removable hand crank for models SW-W 80 and SW-W 125, foldable crank for models SW-W 300 - 750.
- Easy and quick mounting onto walls.

Find out more about this product or get a quotation

Technical data model SW-W

Model	Art.-No.	Capacity 1 st layer kg	Capacity top layer kg	Drum diameter mm	Rope diameter mm	Useable rope length 1 st layer m	Useable rope length top layer m	Lift per crank rotation mm	Required crank effort daN	Weight without rope kg
SW-W 80	040271017	80	45	51	3*	2.4	30	170	12	3
SW-W 125	040271008	125	65	40	4*	2	12	138	13	3
SW-W 300	030271001	300	220	108	5**	2.1	15	68	15	10
SW-W 500	030271136	500	350	108	6**	2.4	15	35	13	11
SW-W 750	030271019	750	550	108	7**	2	10	35	20	11

*recommended rope: DIN 3055 FE-znk 1770 sZ-spa
 **recommended rope: DIN 3060 FE-znk 1770 sZ-spa

Dimensions model SW-W

Model	SW-W 80	SW-W 125	SW-W 300	SW-W 500	SW-W 750
Art.-No.	040271017	040271008	030271001	030271136	030271019
A, mm	110	110	250	250	250
B, mm	110	110	250	250	250
C, mm	130	130	290	290	290
D, mm	130	130	290	290	290
Ø E, mm	9	9	14.5	14.5	14.5
F, mm	15	15	2	2	2
H, mm	121	121	85	85	85
I, mm	55	55	138	138	138
J, mm	-	-	117	117	117
K, mm	250	250	250	250	250
L, mm	130	130	130	130	130
M, mm	68	68	39	39	39
O, mm	60	60	50	50	50
P, mm	275	275	192	192	192

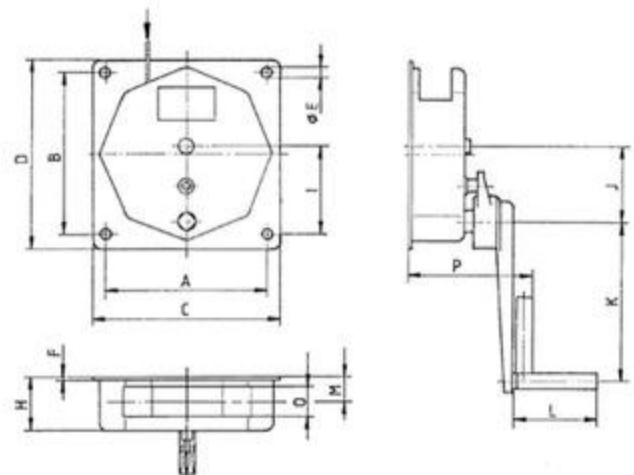

DLHONLINE

Wall-mounted winch model SW-W ALPHA

Capacity 300 - 1000 kg

A versatile wall-mounted winch for an easy lifting of loads.

Features

- Light weight robust stamped steel housing and compact design.
- Spur gear drive for optimal efficiency and comfortable handling.
- Rope lead-offs to all directions.
- All parts are zinc-plated for increased corrosion protection, drum with additional special coating.
- Integrated crank with load pressure brake for safe holding of the load.
- Easy and quick mounting onto walls.

Options

- Foldable crank with tiltable handle for use in confined spaces.
- Variable crank with adjustable crank handle.



Option: Foldable crank with tiltable handle for use in confined spaces.



Option: Variable crank with adjustable crank handle.

Find out more about this product or get a quotation

Technical data model SW-W ALPHA

Model	Art.-No.	Capacity 1 st layer kg	Capacity top layer kg	Drum length mm	Rope diameter* mm	Useable rope length 1 st layer m	Useable rope length top layer m	Lift per crank rotation mm	Required crank effort daN	Weight without rope kg
ALPHA 300	030272006	300	130	50	5	1.3	28	57	13	10
ALPHA 500	030272005	500	230	50	6	1	20	55	17	10
ALPHA 750	030272002	750	270	50	7	1	26	45	17	16
ALPHA 1000	030272001	1000	360	50	7	1	26	45	18	16

*recommended rope: DIN 3060 FE-znk 1770 sZ-spa

! For a better guiding of the rope to the suspension point we recommend the use of sheaves or sheave blocks, see page 83.

Dimensions model SW-W ALPHA

Model	ALPHA 300	ALPHA 500	ALPHA 750	ALPHA 1000
Art.-No.	030272006	030272005	030272002	030272001
A, mm	234	234	306	306
B, mm	262	262	337	337
C, mm	274	274	357	357
D, mm	203	203	265	265
E, mm	107	107	107	107
F, mm	194	194	194	194
G, mm	183	183	255	255
Ø H, mm	63	63	63.5	63.5
I, mm	200	250	250	320
J, mm	58.6	58.6	92.5	92.5
K, mm	109.5	109.5	107	107

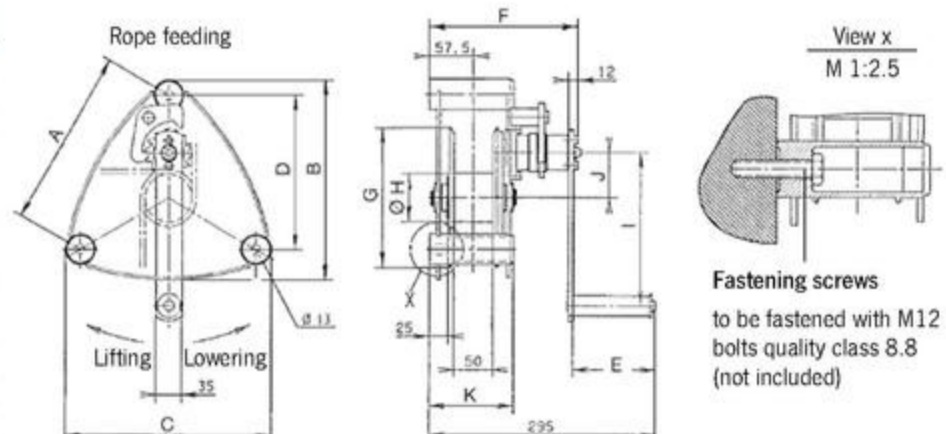

DLHONLINE



Wall-mounted winch with worm gear drive model SW-W-SGG

Capacity 250 - 750 kg

The robust manual rope winches with enclosed worm gear are used in the agricultural industry and in the marine sector.

Features

- Winch housing with enclosed worm gear and additional load pressure brake of solid casting design for a long service life.
- The oil bath lubricated worm gear ensures quiet running characteristics.
- Easy and quick mounting.
- The crank arm is adjustable and makes it possible to work faster with small loads.

DISCONTINUED

Technical data model SW-W-SGG

Model	Art.-No.	Capacity 1 st layer kg	Capacity top layer kg	Drum diameter mm	Rope diameter* mm	Useable rope length 1 st layer m	Useable rope length top layer m	Lift per crank rotation mm	Required crank effort daN	Weight without rope kg
SGG 250	030242004	250	210	96	5	4.8	17.9	20	9.2	12
SGG 500	030243000	500	425	125	6	8.1	28.8	26	14.5	22
SGG 750	030244007	750	624	150	8	9.2	48	20	16	43

*recommended rope: DIN 3060 FE-znk 1770 sZ-spa

Technical data model SW-W-SGG

Model	SGG 250	SGG 500	SGG 750
Art.-No.	030242004	030243000	030244007
A, mm	205	250	330
B, mm	137	190	243
C, mm	120	150	205
D, mm	85	100	125
Ø E, mm	135	182	240
F, mm	219	282	350
G, mm	94	138	182
Ø H, mm	96	125	150
J, mm	310	476	576
K, mm	108	238	238
L, mm	96	112	160
M, mm	79	101	146
N, mm	295	430	440
Ø O, mm	12	14	20
P, mm	237	290	390
Q, mm	13	18	20
R, mm	21	25	32

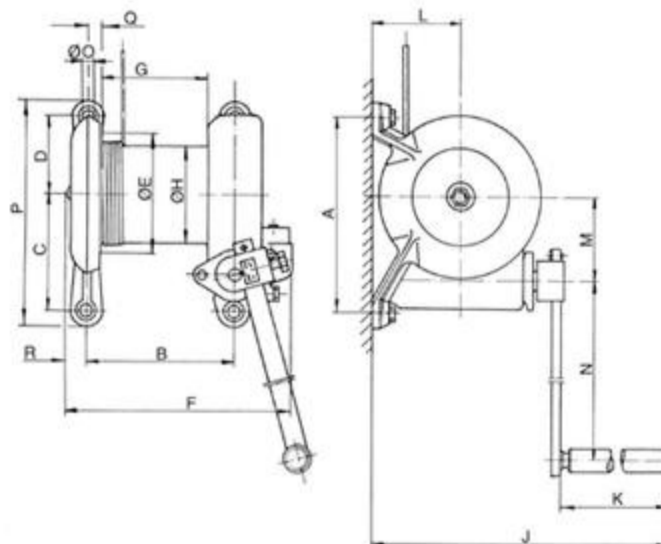

DLHONLINE

Wall-mounted winch with worm gear drive model SW-W-SGO

Capacity 250 - 5000 kg

Wall-mounted winch with worm gear drive and load pressure brake for efficient lifting of heavy loads.

Features

- Housing and rope drums made out of robust steel plate.
- Worm gear drive with additional load pressure brake for safe holding of the load.
- Roller bearings ensure smooth running of the rope and increased lifetime of the winch.
- Second speed for fast lifting of smaller loads, resulting in lowest possible handle effort and rapid winding of the rope (for capacities of 2000 kg and above).
- Large drum capacity with two rope outlets.
- Variable crank with adjustable crank handle for capacities up to 1500 kg.
- Easy and quick mounting.



Model SW-W-SGO
Capacity 1500 kg

Find out more about this product or get a quotation

Technical data model SW-W-SGO

Model	Art.-No.	Capacity 1 st layer kg	Capacity top layer kg	Rope diameter* mm	Useable rope length 1 st layer m	Useable rope length top layer m	Lift per crank rotation mm	Required crank effort daN	Weight without rope kg
SGO 250	040251003	250	100	5	2.3	44	29	6	13
SGO 500	040252026	500	238	6	3.7	54	30	11	16
SGO 1000	040253006	1000	500	9	4.5	46	21	10.6	26
SGO 1500	040253000	1500	850	10	4.5	38	18	16	28
SGO 2000	030254002	2000	1100	13	4	37	8/16**	9/18**	60
SGO 3000	030255009	3000	2000	16	5	34.5	7/14**	12/24**	78
SGO 5000	030256013	5000	3300	20	4.5	33.8	8/16**	25.2/50.4**	105

*recommended rope: DIN 3060 FE-znk 1770 sZ-spa **1st/2nd speed

Dimensions model SW-W-SGO

Model	SGO 250	SGO 500	SGO 1000	SGO 1500	SGO 2000	SGO 3000	SGO 5000
Art.-No.	040251003	040252026	040253006	040253000	030254002	030255009	030256013
A, mm	238	269	302	302	410	436	436
B, mm	145	160	195	250	310	365	425
C, mm	100	115	141	178	196	251	316
D, mm	192	223	254	254	360	386	386
G, mm	106	107	110	111	137	137	137
H, mm	102	131	160	160	176	204	200
Ø J, mm	48	70	102	102	133	165	219
Ø K, mm	14	14	17	17	25	25	25
Ø L, mm	160	190	240	240	312	376	437
M, mm	191	221	266	278	383	443	495
N, mm	15	15	15	15	45	47	60
O, mm	354	384	429	441	-	-	-
P, mm	280	325	350	350	380	380	380
R, mm	171	192	264	306	420	527	604
S, mm	130	130	130	130	220	220	220

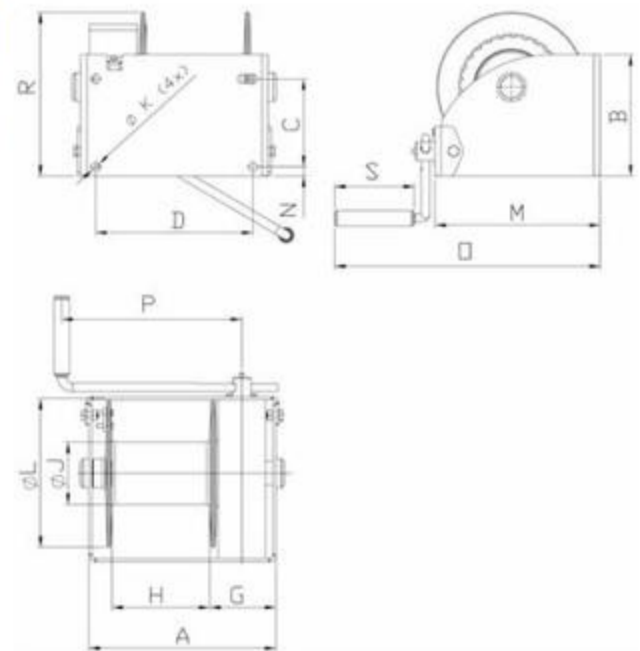

DLHONLINE



Model SW-K GAMMA
Capacity 800 kg

Console-mounted aluminium rope winch model SW-K GAMMA

Capacity 200 - 800 kg

Due to its rugged design, the aluminium rope winch is suitable for operation outdoors.

Features

- Compact aluminium housing and enclosed sprocket wheel drive. From a capacity of 500 kg with speed increasing ratio for small loads and quicker winding and unwinding of the unloaded rope.
- Spur gear drive for optimal efficiency and comfortable handling.
- Enclosed gear for the protection of parts inside, also for arduous applications.
- Low-friction shaft sliding bearings for improved rope lead-off and a longer service life of the winch.
- Wide rope drum for a large rope capacity with two rope attachment points.
- Easy and quick mounting.
- With integrated safety spring brake system and removable crank. The winches can be operated from either side.

Pfaff winches are not designed for passenger elevation applications and must not be used for this purpose.



Model SW-K GAMMA
Capacity 500 kg

Technical data model SW-K GAMMA

Model	Art.-No.	Capacity 1 st layer kg	Capacity top layer kg	Rope diameter* mm	Useable rope length 1 st layer m	Useable rope length top layer m	Lift per crank rotation mm	Required crank effort daN	Ratio	Weight without rope kg
GAMMA 200	040270004	200	110	4	3.6	40	195	19	-	6
GAMMA 500	040270001	500	200	6	4.2	50	60/400**	12	6.57:1	14
GAMMA 800	040270006	800	350	7	5.3	78	36/280**	18	7.57:1	16

*recommended rope: DIN 3060 FE-znk 1770 sZ-spa

**load/speed increasing ratio

Find out more about this product or get a quotation

Dimensions model SW-K GAMMA

Model	GAMMA 200	GAMMA 500	GAMMA 800
Art.-No.	040270004	040270001	040270006
A, mm	120	120	200
B, mm	160	220	326
C, mm	192	330	336
D, mm	152	100	180
E, mm	165	267	327
F, mm	135	125	250
Ø G, mm	9.5	11	14
Ø H, mm	50	60	70
L, mm	320	250	320
M, mm	207	165	207

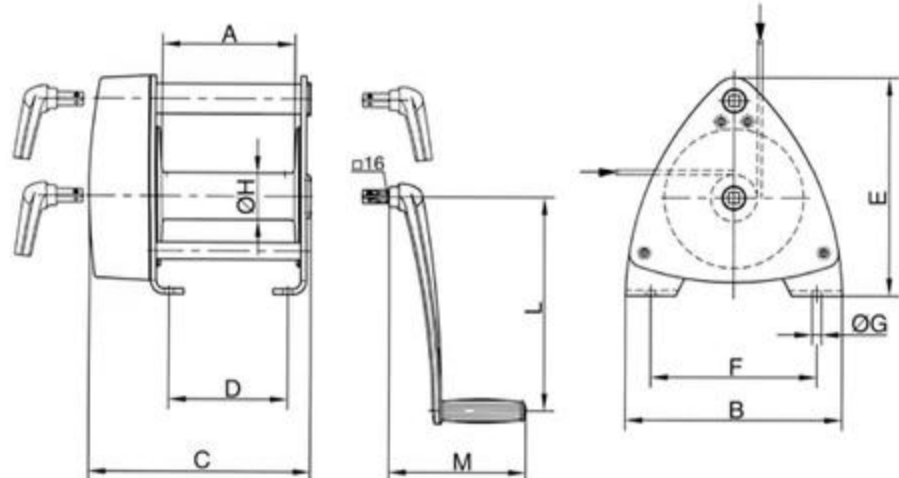

DLHONLINE

Compact aluminium rope winch with free-wheeling device model SW-KAL

Capacity 750 - 1120 kg

Console-mounted rope winches are used for super-structures on vehicles and trailers and when lifting and lowering loads.

Features

- Self-locking worm gear, free-wheeling device for ease of operation.
- Enclosed gear for the protection of internal parts, also for arduous applications.
- Low-friction shaft bearings for a longer service life of the winch.
- Easy and quick mounting.



Find out more about this product or get a quotation

Technical data model SW-KAL

Model	Art.-No.	Capacity 1st layer	Capacity top layer	Drum diameter	Rope diameter*	Useable rope length 1 st layer	Useable rope length max.	Lift per crank rotation	Lift per crank rotation top layer	Required crank effort	Weight without rope
		kg	kg	mm	mm	m	m	mm	mm	daN	kg
KAL 750	030207004	750	600	100	6	1.3	10	15	17	20	7
KAL 1120	030208000	1120	600	63	7	0.5	10	11	16	22	7

*recommended rope: DIN 3060 SE-znk 1770 sZ-spa

Dimensions model SW-KAL

Model	KAL 750	KAL 1120
Art.-No.	030207004	030208000
A, mm	165	165
B, mm	168	168
C, mm	170	170
Ø D, mm	100	63
E, mm	180	180
F, mm	135	135
G, mm	60	60
H, mm	56	50
J, mm	160	160
Ø K, mm	13	13
L, mm	85	85

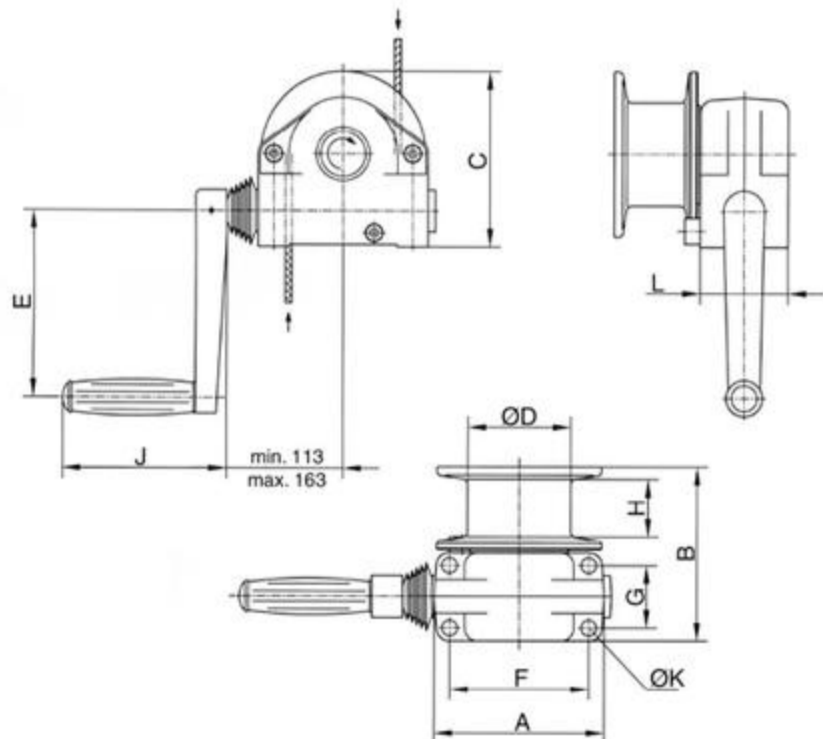

DLHONLINE



Console-mounted rope winch model SW-K LAMBDA (BGVC1)

Capacity 300 kg

The compact rope winch for applications on stages, in studios, theatres, etc.

Features

- State-of-the-art design with galvanized side sections for easy handling.
- Grooved drum for single-layer winding of the steel rope. An 18:1 ratio between drum and rope diameter increases the service life of the rope substantially.
- With spring-loaded rope pressure roller to prevent the unloaded rope from jumping off the drum.
- Gear rated for twice the nominal load.
- Spur gear drive for optimal efficiency and comfortable handling.
- The fitted safety crank with two spring brakes acting independently of each other for safe holding of the load in any position.
- Complies with the latest accident prevention regulations BGVC1 (DIN 56925) as well as the prototype and safety test (GS-test – tested safety) of the German committee for lifting equipment.

Options

- Drum extension for a larger rope capacity.
- Special grooves (several ropes)

! Pfaff winches are not designed for passenger elevation applications and must not be used for this purpose.

▶ Find out more about this product or get a quotation

Technical data model Lambda (BGVC1)

Art.-No.	Capacity kg	Rope diameter* mm	Useable rope length 1 st layer m	Lift per crank rotation mm	Required crank effort daN	Ratio	Weight without rope kg
030272015	300	6	10	50	18	8.83:1	30
030272017	300	6	15	50	18	8.83:1	36

*recommended steel rope: 6 DIN 3069 SE-znk 1960 sZ-spa, (breaking load of the rope min. 30.4 kN)

Dimensions model Lambda (BGVC1)

Art.-No.	030272015	030272017
A, mm	379	469
B, mm	310	310
C, mm	340	340
Ø D, mm	139.4	139.4
E, mm	180	270
F, mm	280	280
G, mm	175	265
Ø H, mm	13	13
J, mm	250	250
K, mm	130	130

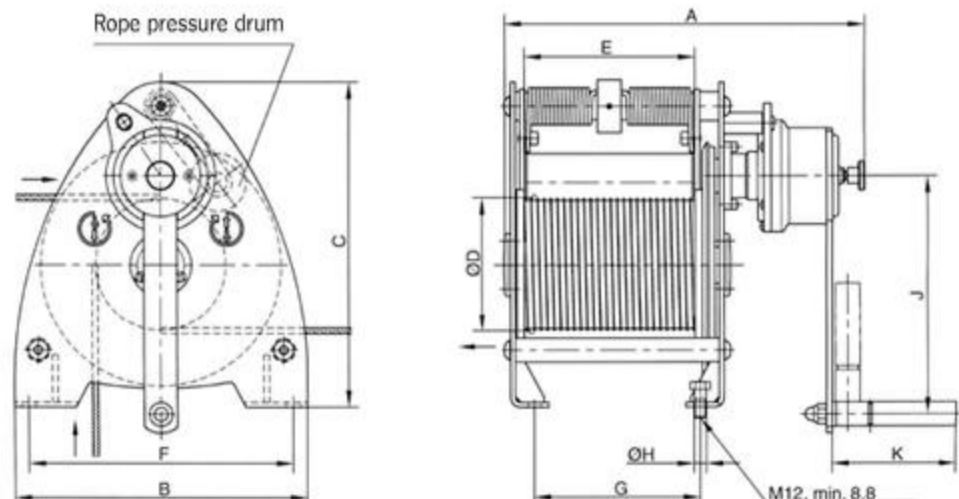

DLHONLINE

Sheave block
for rope guidance,
equipped with ball bearings
model DSRB S



Technical data model DSRB

Model	Art.-No.	Classification FEM/ISO	Pulling force	Pulling force	Rope diameter mm
			in kg at deflection 90°	in kg at deflection 180°	
DSRB S 90/4	033447103	2m/M5	700	500	3-4
DSRB S 90/6	033447413	1Dm/M1	700	500	5-6
DSRB S 145/7	033447106	1Am/M4	1100	800	7
DSRB S 185/8	033447107	2m/M5	2300	1630	8
DSRB S 270/12	033447111	2m/M5	2500	1800	9-12
DSRB S 400/16	033447113	3m/M6	5000	3800	13-16
DSRB S 490/20	033447115	3m/M6	8000	6000	20

All sheaves are available as an individual component on request.

Dimensions model DSRB

Model	DSRB S 90/4	DSRB S 90/6	DSRB S 145/7	DSRB S 185/8	DSRB S 270/12	DSRB S 400/16	DSRB S 490/20
Art.-No.	033447103	033447413	033447106	033447107	033447111	033447113	033447115
B, mm	85	85	125	138	191	302	313
C, mm	90	90	160	195	290	430	580
Ø D, mm	90	90	145	185	270	400	490
Ø D1, mm	20	25	25	30	40	50	65
Ø Dm, mm	80	78	126	160	246	368	450
E, mm	62	62	88	106	138	212	220
H, mm	134	134	224	273	407	612	694
K, mm	65	65	110	135	202	310	340
L, mm	120	120	200	245	360	530	650
Ø M/M1, mm	9/9	9/9	11.5/13	13.5/15	18/20	26/30	34/40
S, mm	4	6	6	8	10	15	16

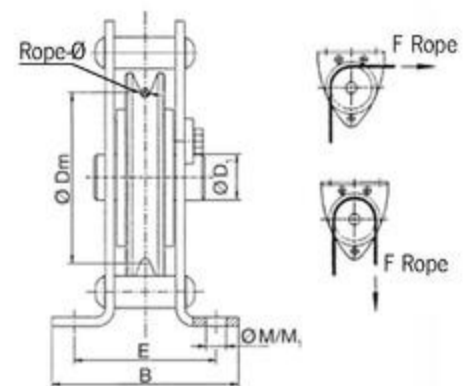
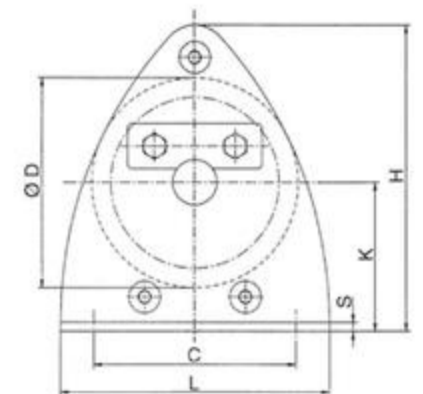

Find out more about this product or get a quotation

Standard ropes for
Pfaff-silberblau manual winches

According to DIN 3060

Article-numbers

Rope diameter	Breaking load of rope min. kN	Useable rope length 5 m	Useable rope length 10 m	Useable rope length 15 m	Useable rope length 20 m	Capacity clevis end kg
4 mm - DIN 3060	10.1	033600405	033600410	033600415	033600420	500
5 mm - DIN 3060	15.8	033600505	033600510	033600515	033600520	1000
6 mm - DIN 3060	22.8	033600605	033600610	033600615	033600620	1000
7 mm - DIN 3060	31.0	033600705	033600710	033600715	033600720	1000
7 mm - DIN 3069*	43.9	-	-	033601715	-	1600

*Rope with increased breaking load for LB 1200 kg

**Additional accessories
available on request.**

**Contact us on
0161 223 990**

DLHONLINE



Manual winch with spur gear drive model MWS

Capacity 150 - 1500 kg

For the operation where no electricity is available or in a dirty environment.

Recommended rope diameter according to DIN 3060 FE-znk 1770 sZ-spa.

The rope is not part of the delivery package.

Features

- Enclosed gear drive for protection of internal parts, even under tough working conditions.
- Spur gears on roller bearings, rope drum on plain bearings.
- Compact design.
- Easy and quick mounting onto walls, poles etc.
- They have a self-locking, anti-kickback and adjustable crank handle for fast lifting of smaller loads, resulting in lowest possible handle effort and rapid winding of the rope.
- Automatic load pressure brake for safe holding and extremely sensitive lowering of the load. Unintentional brake release is prevented even with swinging loads.
- They are suitable for operation in ambient temperatures of -20 °C up to +40 °C.

Option

- Corrosion resistant version

 **Find out more about this product or get a quotation**

 Pfaff winches are not designed for passenger elevation applications and must not be used for this purpose.

DLHONLINE

Technical data model MWS

Model	EAN-No. 4025092*	Capacity 1 st layer	Capacity top layer	Crank effort 1 st layer	Lift per crank rotation 1 st layer	Lift per crank rotation top layer	Ratio	Weight without rope	Rope diameter*	Breaking load of rope min.	Useable rope length 1 st layer	Useable rope length max.	Number of layers max.
		kg	kg	daN	mm	mm		kg	mm	kN	m	m	
MWS 150	*635356	150	68	11	122	210	1:1	4	4	5.7	0.8	13	8
MWS 300	*635363	300	166	6	32	44	1:7.4	10	5	15.9	1.8	21	7
MWS 600	*635370	600	308	10	28	41	1:7.4	11	6	22.9	1.2	12	6
MWS 1000	*635387	1000	587	11	20	27	1:17	27	9	51	3.0	25	5
MWS 1500	*635394	1500	844	12	14	19	1:25.7	27.5	10	63	2.7	21	5

*recommended rope: DIN 3060 FE-znk 1770 sZ-spa

Dimensions model MWS

Model	MWS 150	MWS 300	MWS 600	MWS 1000	MWS 1500
A, mm	65	200	200	230	230
B, mm	168	300	300	340	340
C, mm	128	268	268	280	280
D, mm	40	168	168	180	180
E, mm	303	318	318	485	485
G, mm	26	-	-	-	-
H, mm	40.5	55	55	113	113
J, mm	35	70	60	102	102
K, mm	9	12	12	17	17
L, mm	102	145	145	212	212
M, mm	168	182	182	350	350
N, mm	89	199	199	266	266
O, mm	92	96	96	263	263
S, mm	128.5	128.5	128.5	128.5	128.5

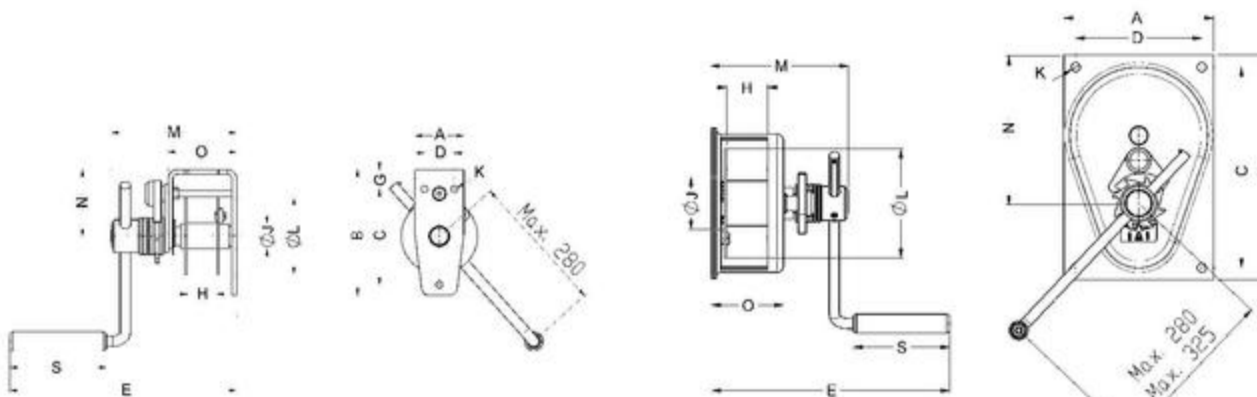

Model MWS, capacity 150 kg

Model MWS, capacity 300 - 600 kg

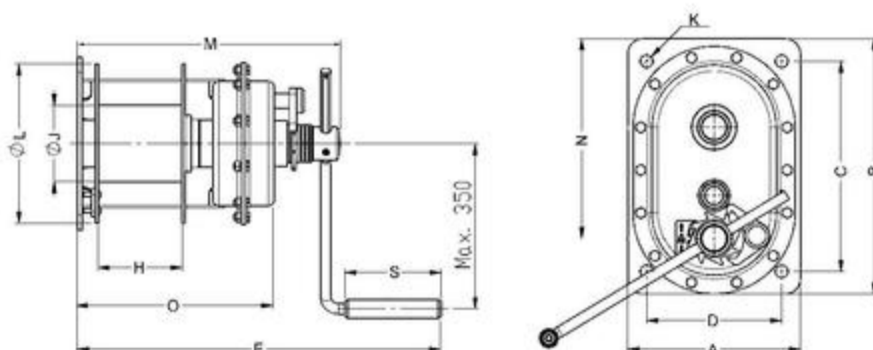

Model MWS, capacity 1000 - 1500 kg

Find out more about this product or get a quotation

DLHONLINE

Cable puller model Yaletrac ST

Pulling force 1000 - 3200 daN

Cable pullers model Yaletrac ST feature a housing of dimensionally stable deep-drawn steel plates ensuring a compact, robust design in combination with optimised weight.

The benefits of the previous Yaletrac range have been maintained and supplemented to the needs of the market. The hand operating forces have been noticeably optimised for the user by the application of axial ball bearings.

Features

- Stable upright positioning of the unit due to the combination of handle and foot.
- Space-saving telescopic hand lever that can be safely attached to the unit by means of a hook-and-pile fastener.
- Increased service life of the unit due to the use of rubber sleeves which prevent dirt and dust from penetrating into the mechanical equipment of the unit.
- Positioning of the forward and reversing levers in tandem provides a slim design and ensures optimal power transfer.
- Overload protection is provided by a shearing pin. Spare shear pins are conveniently located in the carrying handle. A broken pin can be replaced without removing the load.
- A lever disengages the rope clamp system allowing easy and smooth installation of the rope.
- Yaletrac ST uses a special flexible rope. It has six strands with a steel core and is identified by an orange strand. The rope is tapered at one end for easy threading and is fitted with an eye sling hook with safety latch on the other end.
- The parallel arrangement of the clamping system protects the rope by distributing the clamping forces evenly. A long rope advance per each lever stroke increases the working speed.
- The large opening in the top of the unit allows easy cleaning: simply flush the unit with water and apply motor oil for lubrication and the Yaletrac ST is again ready for use.



! Yale hoists and trolleys are not designed for passenger elevation applications and must not be used for this purpose.

Contact us for prices
on 0161 223 1990



Option:
Eye sling hook with safety latch



Option:
Yaletrac storage box made from steel plate,
approx. 74x26x45 cm

Options

- Eye sling hook with safety latch
- Longer ropes
- Drum reel
- Storage box



DLHONLINE

Technical data model Yaletrac ST

Model	EAN-No. 4025092*	Capacity WLL kg	Rope advance per double stroke in mm	Lever pull at WLL daN	Lever length mm	Rope diameter mm	Weight without rope kg	Rope weight kg/m
Y 10 ST	*422901	1000	60	23	800	8.4	8.5	0.29
Y 16 ST	*422925	1600	60	28	790/1190	11.5	15.8	0.53
Y 32 ST	*422963	3200	40	46	790/1190	16	27.2	1

Dimensions model Yaletrac ST

Model	Y 10 ST	Y 16 ST	Y 32 ST
L, mm	435	560	664
H, mm	178	205	240
H1, mm	235	280	350
B, mm	61	86	96
B1, mm	94	125	123

Contact us for prices
on 0161 223 1990

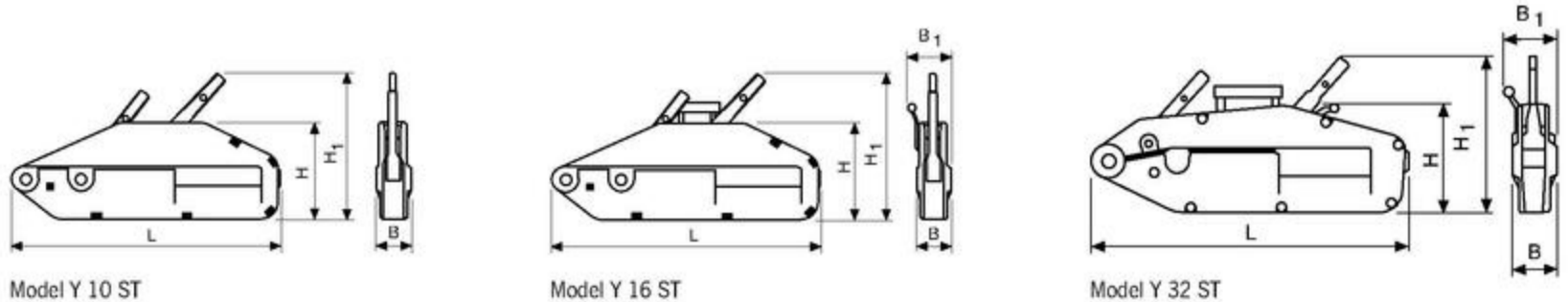

Rubber sleeves prevent dirt from penetrating into the mechanical equipment and thus increase the service life

Rope clamp disengagement lever for easy installation of the rope

Axial ball bearings for optimised hand operating forces

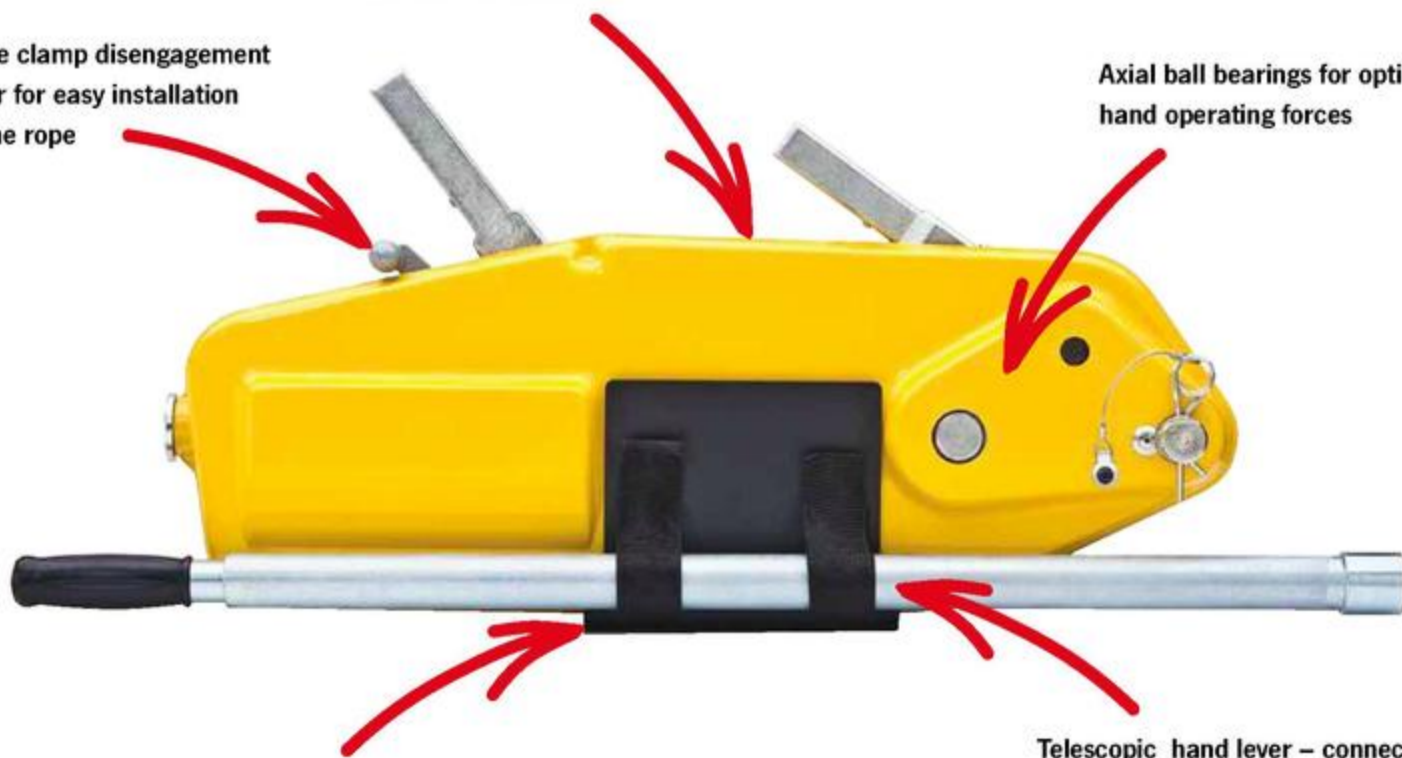

Foot for stable positioning of the unit

Telescopic hand lever – connected to the unit safely for transportation.

DLHONLINE



Cable puller model Yaletrac

Pulling force 800 - 3200 daN

It has a light weight, compact, high tensile aluminium alloy housing with a large flat bottom surface for increased stability in horizontal as well as vertical working position.

Features

- Forward and reversing levers in tandem provide slim design and assure power transfer along the centre line.
- Overload protection is by a shearing pin in the forward lever. Spare shear pins are conveniently located in the carrying handle or operating lever. A broken pin can be replaced without removing the load.
- A lever disengages the rope clamp system allowing easy, smooth installation of the rope.
- Yaletrac uses a special flexible rope. It has six strands with a steel core and is identified by an orange strand. The rope is tapered at one end for easy threading and fitted with an eye sling hook with safety latch on the other end.
- The parallel arrangement of the clamping system protects the rope by distributing the clamping forces evenly. A long rope advance per each lever stroke increases the working speed.
- The large opening in the top of the unit allows easy cleaning: simply flush the unit with water, apply motor oil for lubrication and the Yaletrac is again ready for use.

Options

- Eye sling hook with safety latch
- Longer ropes
- Drum reel
- Storage box

Yale hoists and trolleys are not designed for passenger elevation applications and must not be used for this purpose.

Find out more about this product or get a quotation

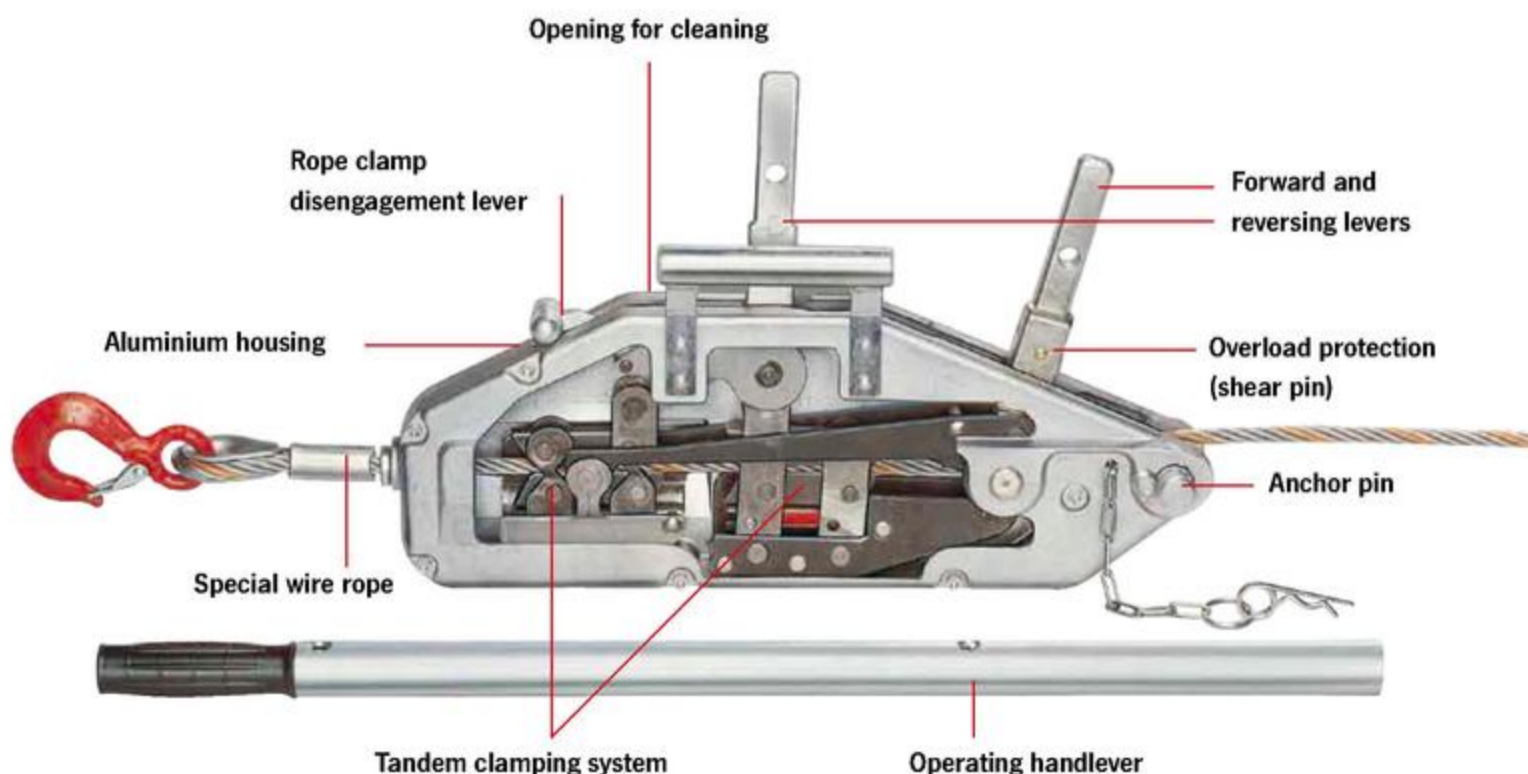

DLHONLINE

Technical data model Yaletrac

Model	EAN-No. 4025092*	Capacity WLL kg	Rope advance per double stroke in mm	Lever pull at WLL daN	Lever length mm	Rope diameter mm	Weight without rope kg	Rope weight kg/m
Y 08	*051811	800	60	24	800	8.4	7	0.29
Y 16	*051828	1600	60	30	790/1190	11.5	14	0.53
Y 32	*078870	3200	40	50	790/1190	16	21	1

Dimensions model Yaletrac

Model	Y 08	Y 16	Y 32
L, mm	430	545	680
H, mm	168	190	230
H1, mm	240	270	330
B, mm	60	72	91
B1, mm	-	97	110

Find out more about this product or get a quotation

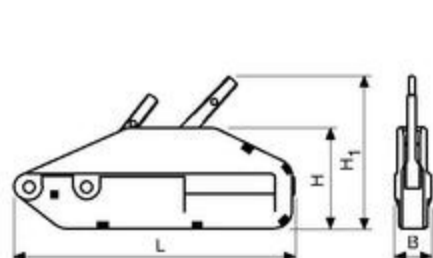

Model Y 08

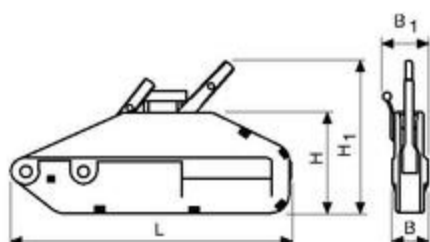

Model Y 16

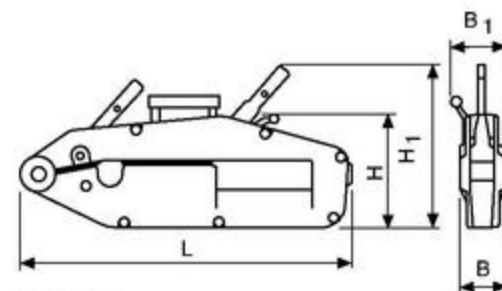

Model Y 32



Option:
Yaletrac storage box made from steel plate,
approx. 74x26x45 cm



Option:
Eye sling hook with safety latch

DLHONLINE



Cable puller model LP

Capacity 500 kg

A practical aid for pulling, lifting, tensioning and lowering in many applications in- and outdoors.

A compact, handy tool – ideal for service and assembly, for workshops and recreation.

Features

- The stamped steel housing is lightweight and resistant.
- The complete set comprises of a cable puller with anchor bolt and eye sling hook, telescopic operating lever, 10 metres of wire rope, carrying handle and a webbing sling of 1 metre length which can be used as a rigging point.

Find out more about this product or get a quotation

Technical data model LP

Model	EAN-No. 4025092*	Capacity WLL kg	Rope advance per double stroke mm	Lever pull at WLL daN	Lever length mm	Rope diameter mm	Weight without rope and lever kg
LP 500	*051804	500	35	15	600	8.3	4

! Yale hoists and trolleys are not designed for passenger elevation applications and must not be used for this purpose.

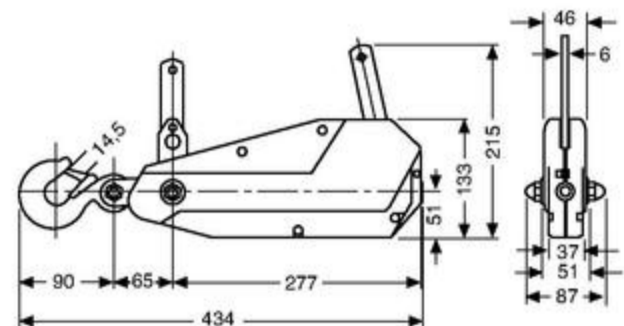

DLHONLINE

Cable puller model LM

Pulling force 500 - 1800 daN

The use of aluminium alloy castings provide a lightweight, corrosion resistant unit for pulling and tensioning applications. The double interlocking pawl system ensures safe function, all load bearing shafts are mounted on prelubricated bearings to reduce wear.

Features

- All springs and shafts are manufactured from stainless steel. The lifting medium is a non-twisting, galvanized, special steel wire rope.
- The hooks are fitted with safety latches and are free to rotate 360°.
- The cable puller LM can be used in single or double legged configuration. In double legged configuration the pulling force is doubled and the lifting height is halved.



Find out more about this product or get a quotation

! Yale hoists and trolleys are not designed for passenger elevation applications and must not be used for this purpose.

Technical data model LM

Model	EAN-No. 4025092*	1 legged design			2 legged design			Weight kg	Lever length mm	Hook- opening mm	Rope diameter mm
		pulling force daN	hook path m	headroom mm	pulling force daN	hook path m	headroom mm				
115 DV-B	*077293	500	4.6	550	1000	2.3	700	4.5	420	22	4.8
202 WN-VB	*077309	500	6.0	525	1000	3.0	690	5.2	520	22	4.8
434 WN-VB	*077316	500	9.0	550	1000	4.5	710	5.8	530	22	4.8
S 434 WN-VB	*077491	700	6.0	565	1400	3.0	725	6.0	530	22	5.6
S 404 WN-VB	*077323	900	5.2	575	1800	2.6	720	5.9	635	22	6.4

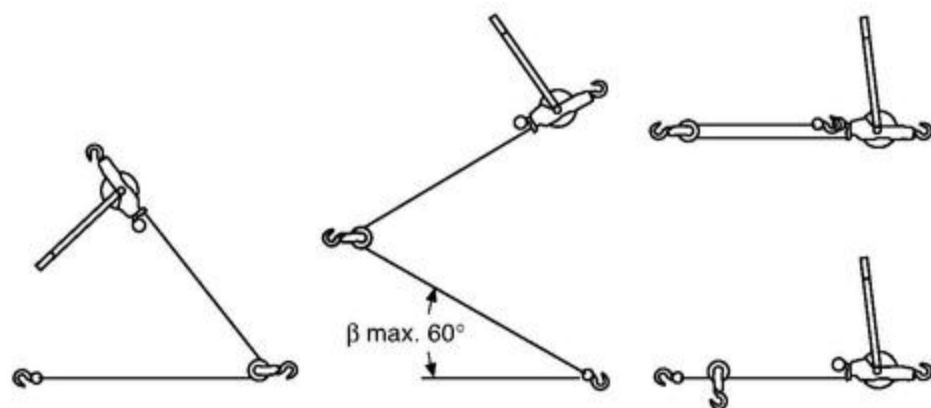

Rigging configurations - Attention! reduced capacity

! The units may only be used for pulling and tensioning. Lifting and lowering of loads is not permitted.

DLHONLINE



Pulley blocks, hinged, with single steel sheave

Capacity 1000 - 6400 kg

One side of the Yale pulley blocks is hinged and can be opened for easy and quick positioning of the wire rope on the sheave. It can also provide a quick and versatile rigging point or redirect a wire rope.

Features

- Swinging the hook in the direction of pull securely locks the pulley block.
- The high quality cast steel sheaves have machined grooves and are fitted with Permaglide® bushes.
- When choosing and classifying pulley blocks, take the "Principles for Rope Drives" DIN 15020 into consideration.

Yale hoists and trolleys are not designed for passenger elevation applications and must not be used for this purpose.

Find out more about this product or get a quotation

Technical data pulley blocks

Model	EAN-No. 4025092*	Capacity kg	Rope diameter mm	Weight kg
Pulley blocks 1000	*455817	1000	7	3.3
Pulley blocks 2000	*455794	2000	13	8.9
Pulley blocks 3200	*455800	3200	15	15.5
Pulley blocks 6400	*455824	6400	18	26.5

Dimensions pulley blocks

Model	Pulley blocks 1000	Pulley blocks 2000	Pulley blocks 3200	Pulley blocks 6400
B, mm	118	199	230	270
B1, mm	76	92	108	116
B2, mm	17	24	28	35
C, mm	23	27	31	42
Ø D1, mm	85	150	180	210
Ø D2, mm	105	190	220	260
L, mm	305	425	496	655
L1, mm	200	263	295	375
L2, mm	23	30	40	47
R, mm	4	7	9	10

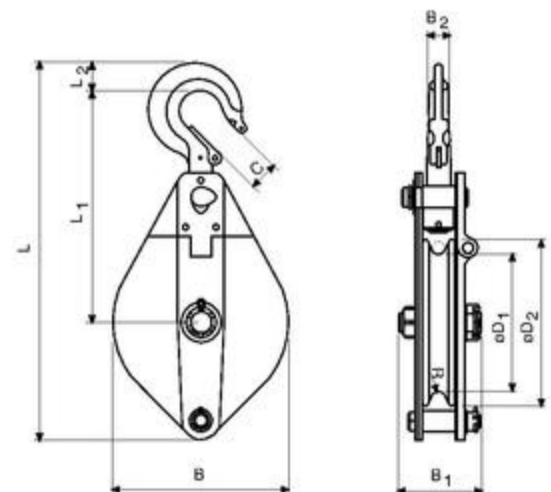

DLHONLINE

Cable grip model LMG

Pulling force 2000 - 5000 daN

The LITTLE MULE[®] cable grip is a device for gripping, pulling and tensioning uncoated wire ropes, cables and metal rods in all forms up to a tensile strength of 1770 N/mm² but is dependant on the diameter and surface condition.

The parallel jaws provide a firm, non-slip grip without causing damage to the wire rope. A special spring-loaded guide prevents the grip from dropping off the wire rope and allows instant release without jamming.

The model LMG II-X is supplied with grooved jaws and is suitable for wire ropes with a tensile strength of up to 1960 N/mm², but is dependant on the rope diameter and surface condition.



Find out more about this product or get a quotation

Technical data model LMG

Model	EAN-No. 4025092*	Pulling force daN	For rope diameter mm	Eye opening mm	Weight kg
LMG I	*052214	2000	5 - 15	31x44	1.6
LMG II	*052221	3000	8 - 20	31x44	2.9
LMG II-X	*052245	3000	8 - 20	31x44	2.9
LMG III	*052238	5000	18 - 32	66x93	9.5

! Yale hoists and trolleys are not designed for passenger elevation applications and must not be used for this purpose.

DLHONLINE

Steel rope for manual and electric winches

All Pfaff-silberblau electric winches are supplied without load bearing mechanisms as standard. To ensure safe operation an optimum rope design, optimum length and associated fastening elements (hooks, shackles) are selected.

We recommend to choose wire ropes on the basis of design, type of construction and strength to suit the intended use and frequency of use. The features of the different types of rope design are as follows:

Breaking load

→ Load bearing capacity, strength of the rope

Bending fatigue + flexibility

→ Service life

External wear

→ Stability of the outer strands

Torsion characteristics

→ Lifting of guided or unguided loads

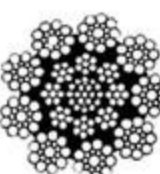
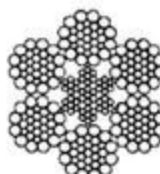
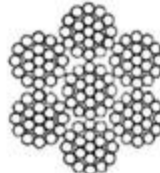

Handling

Our product range includes winches for lifting, pulling and moving of loads. In combination to our winches the following rope types apply:

Standard design

DIN 3060 - 6 x 19 + FE 1770 N/mm²

Manual winch rope with fiber inlay 3 - 12 mm Ø

Galvanized or stainless steel in mat. 1.4401

Nominal strength 1570 N/mm² (low breaking load)

- not non-twisting
- crosslay type of construction
- low-tension
- lifting rope for infrequent actuation
- rugged and widely resistant

Warrington-Seale

6 x 36 WS + SES (FE) 1770 N/mm²

Manual and electric winch rope in parallel type of construction, 10 - 28 mm Ø

Galvanized, with fiber or steel inlays as options

- highly flexible
- high breaking load
- average number of reversed bending stresses

Non-rotating special rope

SE-znk - 1960 N/mm²

Standard rope for electric winches

Non-rotating spiral strand rope, 3 - 13 mm Ø

Galvanized

- balanced characteristics
- lifting rope for unguided single rope suspension elements
- lifting rope for large lifting heights with multiple rope suspension elements
- not to be used with a swivel
- high strength
- high bending fatigue characteristics

Heavy duty winch rope

Electric winch rope with plastic-coated steel core in double-parallel type of construction, 6 - 30 mm Ø

Bright and greased, not non-twisting

- special rope for frequent bending stress reversals and long use.
- to be used only with matching rope sheaves and drums.
- optimized break loads due to higher fill factor.

The use of plastic-coated steel wire ropes with lifting equipment is not permitted.

To meet individual requirements we can provide assistance for the selection of length, diameter and type of the rope, as well as a fastening equipment (thimbles, hooks, rope clips, etc.).

DLHONLINE

Rope fasteners/rope connections

The safe functioning of the rope drive depends to a large extent on the rope fastenings on the winch and on the load. Rope connections and ropes themselves have to be checked at regular intervals by competent persons. The following rope connections are permissible for use with lifting equipment:

Non-releasable rope connections

Aluminium press-on connection with thimbles

in combination with safety eye hooks or screw shackles provide a simple and safe means of suspending loads.

Splice connections DIN 3089 (uncoated)

in combination with thimbles, hooks, etc.

In the most unfavourable situation, splice connections can lead to a reduction in the breaking load of the rope line of up to 40%.

Pressed and splice connections may only be produced by specialist firms or rope manufacturers.

Releasable rope connections:

Rope clips

- The end which is not under load must never be fastened to the load-bearing line.
- The length of the unloaded rope end should be at least 20 times the diameter of the rope and not less than 150 mm.
- Clips may no longer be used once the rope has worn by more than 10%.
- Wire rope clamps may not be used for rope connections for lifting equipment, with the exception of fastening equipment which is manufactured for non-recurring, special purposes!

Notes on the installation of winches:

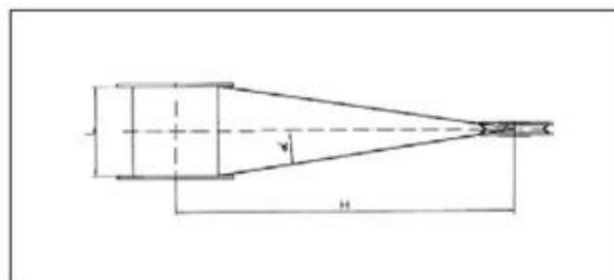

The distance between rope drum and sheave must be selected in a way that the maximum deflection angle for the type of rope used is not exceeded:

Standard rope – Deflection angle < 3°
(Minimum distance = Drum width x 10)

Special rope – Deflection angle < 1,5°
(Minimum distance = Drum width x 20)

Handling of ropes – Unwinding

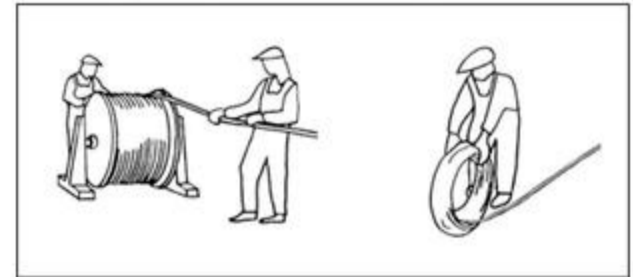

RIGHT

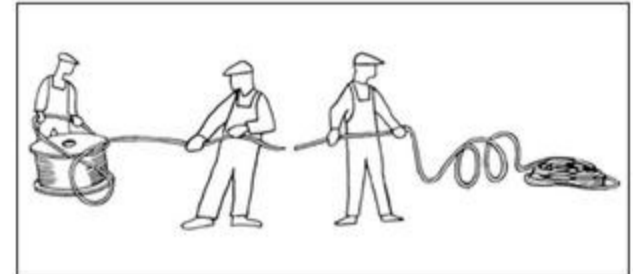

WRONG

Care of ropes

“Running ropes” in particular will only offer optimum service lives if they are well lubricated. The use of steel ropes without grease will cause them to wear quickly and the load bearing mechanism will have to be replaced early.

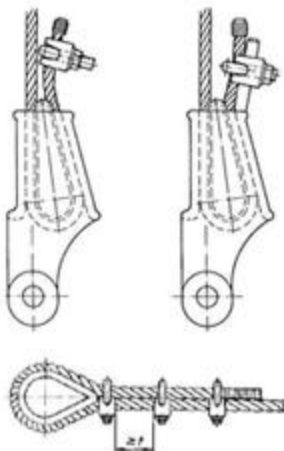
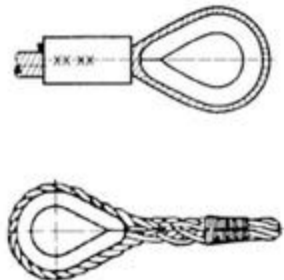

- To prevent the wire rope from becoming slack when unloaded it should always have an additional rope weight when used with lifting equipment.
- Guided loads must be monitored with a slack rope cut-out.
- To prevent the rope from becoming damaged, steel wire ropes must never be guided:
 - over edges
 - over deflection radii which are too small or
 - over rope sheaves with grooves which are too small.
- High dynamic forces can lead to sudden breaks or crashes of the load. It is therefore imperative that loads are never brought to a dead stop (“on block”) and that loads are never allowed to drop into the rope.

DLHONLINE



Electric winch model RPE

Capacity 250 - 1000 kg

Winches series RPE and RPA are designed explicitly for performance, efficiency and safety and offer many advantages and options. RPE's and RPA's extremely compact, practical cube design and universal rope lead-offs allow individual applications in almost any position and make them powerful aids for lifting and pulling loads.

The winches are designed to DIN 15020, classification 1 Bm/M3, safety regulation BGV D8 (winch, lift and pull equipment) and, of course, the EC machinery directives.

Every winch is factory tested with overload.

The units are supplied with a test certificate showing the unit's serial-no. and an operating instructions manual which contains a manufacturer's declaration.

Features

- Compact dimensions due to internal brake motor.
- Voltage 400V/230V, 3-phase, 50Hz, protected to IP 54, insulation class F.
- Adjustable slip clutch to protect the winch from overloading standard for model RPE 10-6.
- Spur gear transmission with helical first gear ensures smooth motion. Lubricated by grease and can, therefore, be used in any position.
- Spring pressure disc brake incorporated in the motor holds the load secure even in the event of a power failure.
- Plain rope drum standard.
- The rope is secured to the drum in a recess so that the rope can be wound onto the drum in several layers without damage.
- Direct control or 42 V low voltage control (incl. push-button with emergency-stop and 2 m control cable).

Find out more about this product or get a quotation



Rope attachment



Spring pressure disc brake



Brake motor

When selecting the length of the rope please bear in mind that a minimum of 2.5 windings have to remain on the drum (approx. 1 m rope).

DLHONLINE

Options

- Different drum designs, e.g. extended to accommodate longer rope, machined grooves for exact reeling, with separation web and 2nd rope outlet for working with two ropes.
- Geared limit switches to limit rope motion in both directions (in combination with 42 V low voltage control).
- Single-phase A.C. motor 230 V, 50 Hz, 42 V low voltage control.
- Slack rope switch to automatically stop the winch when rope tension eases e.g. when the load touches down (only in combination with low voltage control).
- Frequency converter for stepless speed control.
- Adjustable slip clutch to protect the winch from overloading for models RPE 2-13, RPE 5-6 and RPE 5-12.
- Special design according to BGV C1 for theater stage applications available.
- Radio remote control
- Other operating voltages
- Stainless brake



Special design for wind energy as well as customised constructions on request.

Also available as zinc-plated version on request.

Find out more about this product or get a quotation



Single-phase A.C. motor



Geared limit switches



Gearbox with slip clutch



Different drum designs

DLHONLINE

Technical data model RPE

Model	EAN-No. 4025092*	Capacity kg	Lifting speed 1 st layer m/min	Lifting speed top layer m/min	Rope diameter mm	Motor kW	ED %	Useable rope length 1 st layer m	Useable rope length top layer m	Weight without rope kg
RPE 2-13	*071796	250	10.2	13.2	4	0.55	40	11.2	54.5	31.8
RPE 5-6	*071857	500	4.6	6.6	6	0.55	40	7.0	38.8	32.8
RPE 5-12	*071918	500	8.7	12.6	6	1.1	40	11.0	55.4	41.0
RPE 9-6	*071956	990	5.1	6.5	8	1.1	40	10.2	37.4	76.0
RPE 10-6*	*072014	1000	5.1	6.5	8	1.1	40	10.2	37.4	76.9

*With slip clutch

Plain drum (longer useable rope length)

Model	Capacity top layer kg	Drum size	Useable rope length max. m
RPE 2-13 L	250	2	80
RPE 5-6 L	500	2	58
RPE 9-6/10-6 L	990/1000	2	56
RPE 2-13 XL	250	3	200
RPE 5-6 XL	500	3	140
RPE 5-12 XL	500	3	140
RPE 9-6/10-6 XL	990/1000	3	100

Grooved drum (recommended for single layer operation)

Model	Capacity top layer kg	Drum size	Useable rope length 1 st layer m	Useable rope length max. m
RPE 2-13 R	250	1	8.8	43
RPE 5-6 R	500	1	6.2	33
RPE 9-6/10-6 R	990/1000	1	8.2	30
RPE 2-13 LR	250	2	13.3	64
RPE 5-6 LR	500	2	9.5	49
RPE 5-12 LR	500	2	9.5	49
RPE 9-6/10-6 LR	990/1000	2	12.9	47
RPE 2-13 XLR	250	3	35.3	165
RPE 5-6 XLR	500	3	25.7	128
RPE 5-12 XLR	500	3	25.7	128
RPE 9-6/10-6 XLR	990/1000	3	25.2	89



Find out more about this product or get a quotation

DLHONLINE

Dimensions model RPE (400V direct control, standard drum)

Model	RPE 2-13	RPE 5-6	RPE 5-12	RPE 9-6	RPE 10-6
A, mm	405	405	405	525	525
B, mm	375	375	375	485	485
C, mm	18	18	18	25	25
DTR, mm	76	76	76	108	108
D max, mm	104	118	118	148	148
DA, mm	150	150	150	180	180
E, mm	338	338	428	450	450
F, mm	210	210	300	270	270
G, mm	260	260	350	345	345
H, mm	290	290	380	380	380
I, mm	11	11	11	13	13
K, mm	250	250	250	340	340
L, mm	125	125	125	170	170
M, mm	6	6	6	10	10
N, mm	33	33	33	47.5	47.5
O, mm	194	194	284	250	250
P, mm	19	19	19	24	24
Q, mm	13	13	13	19	19
R, mm	125	125	125	170	170
S, mm	4	6	6	8	8
$\alpha 1, ^\circ$	130	130	130	145	145
$\alpha 2, ^\circ$	110	110	110	125	125
$\alpha 3, ^\circ$	40	40	40	50	50
$\beta 1, ^\circ$	150	150	150	155	155
$\beta 2, ^\circ$	90	90	90	100	100
$\beta 3, ^\circ$	80	80	80	83	83

*Dimensions for s with optional features are available on request!

Find out more about this product or get a quotation

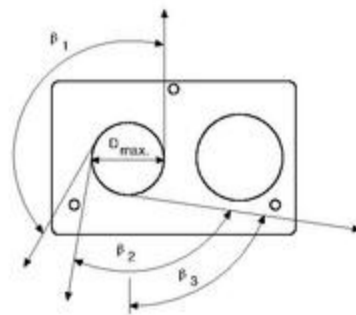
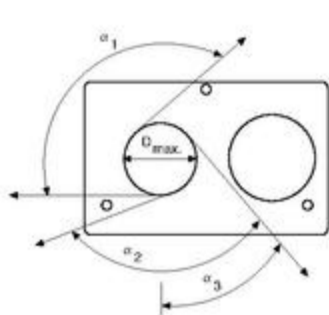
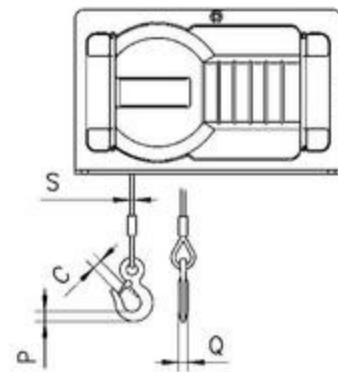
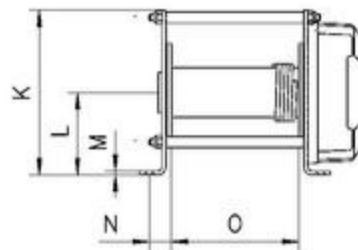
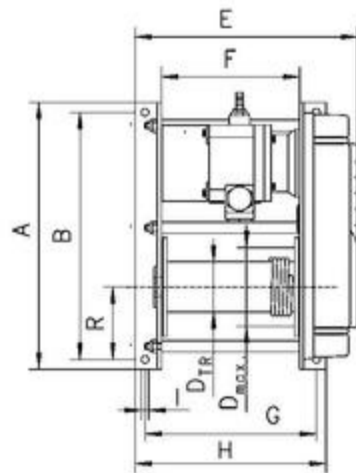

Rope lead-offs for electric winch RPE

Yale winches are not designed for passenger elevation applications and must not be used for this purpose.

DLHONLINE



Pneumatic winch model RPA

Capacity 250 - 500 daN

The conception is in accordance with the design of the model RPE.

With 100% duty rating and an unlimited number of starts the model RPA is suitable for heavy duty applications. It is insusceptible to contamination, humidity and aggressive mediums from the outside.

Features

- Robust rotating piston motor with high starting torque, designed for operating pressures 4 to 6 bar.
- Spring pressure disc brake incorporated in the motor holds the load secure even in the event of an air failure.
- Sensitive control by means of direct acting valves in the control switch.

Options

- Different drum designs, e.g. extended to accommodate longer rope, machined grooves for exact reeling, with separation web and 2nd rope outlet for working with two ropes.
- Control including 2.5 m hose and air coupler.
- Maintenance unit for main air supply pipe (pressure regulator, manometer, lubricator and support).

► Find out more about this product or get a quotation

! To ensure faultless operation the compressed air supply must be filtered and oiled.



Rope attachment



Different drum designs

! Available in corrosion proof version on request!

DLHONLINE

Technical data model RPA

Model	EAN-No. 4025092*	Capacity kg	Lifting speed with rated load* m/min	Lifting speed without load* m/min	Lowering speed with rated load* m/min	Rope diameter mm	Motor kW	Useable rope length top layer m	Weight without rope kg
RPA 2-13	*072397	250	12.5	20	22	4	0.55	54.5	36.7
RPA 5-6	*072458	500	6.2	10	11	6	0.55	38.8	36.7

*Values in the top layer for 6 bar, air consumption 0.75 m³/min

Dimensions model RPA

Model	RPA 2-13	RPA 5-6
A, mm	405	405
B, mm	375	375
C, mm	18	18
DTR, mm	76	76
D max, mm	104	118
DA, mm	150	150
E, mm	336	336
F, mm	210	210
G, mm	260	260
H, mm	290	290
I, mm	11	11
K, mm	250	250
L, mm	125	125
M, mm	6	6
N, mm	33	33
O, mm	194	194
P, mm	19	19
Q, mm	13	13
R, mm	125	125
S, mm	4	6
α 1, °	130	130
α 2, °	90	90
α 3, °	20	20
β 1, °	150	150
β 2, °	70	70
β 3, °	60	60

When selecting the length of the rope please bear in mind that a minimum of 2.5 windings have to remain on the drum (approx. 1 m rope).

Find out more about this product or get a quotation

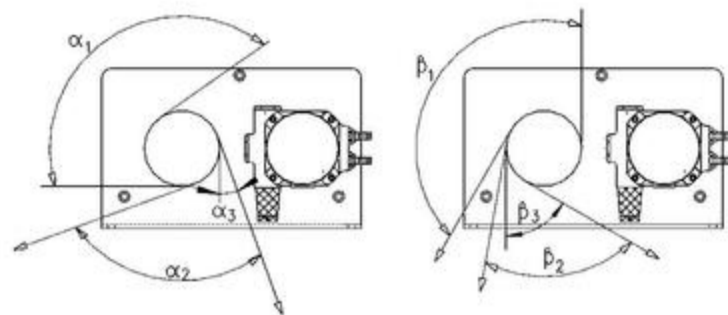

Rope lead-offs for pneumatic rope winch RPA

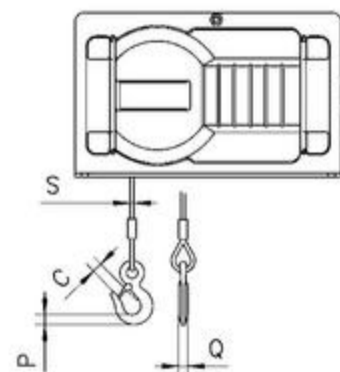
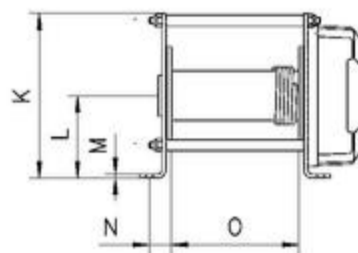
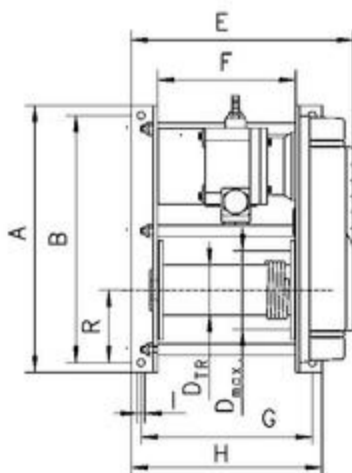

DLHONLINE



! For determining the required rope length, please take into account that at least 2 to 3 windings must remain on the drum!

Electric winch model BETA SILVERLINE

Capacity 125 - 3200 kg

Electric winches of the BETA SILVERLINE range are used for lifting, towing and positioning of loads.

The proven technology and specified equipment features make the winch the ideal product for standard applications.

Features

- The electrically released spring pressure disc brake safely holds the load also in the event of a power failure.
- Powerful three-phase AC drives for multi-range voltage 380 - 420V, 50 Hz or 440 - 460V, 60 Hz. Motor type of enclosure IP55, duty factor 40% ED.
- Electronic overload protection from 1000 kg lifting load as standard.
- The maintenance-free, oil lubricated gearbox has quiet running characteristics due to milled and ground gears with helical teeth.
- All parts with high-quality two component paint (RAL 5015, coat thickness approx. 120 µm), rope drum zinc-plated in addition.
- Standard rope drum of grooved design, with large rope capacity.
- Variable rope lead-in due to two rope attachment points (left and right).
- Contactor control (incl. gear limit switch).
- Complies with accident prevention regulations BGV D8.

! BETA SILVERLINE winches are only available with the specifications shown in this catalogue.

! Additional options and an adaptation for special applications are offered exclusively for model BETA PROLINE (see page 106).

• As PROLINE winches are always customized solutions they are only available on request.

DLHONLINE

Technical data model BETA SILVERLINE

Art.-No. Contactor control	Size	Capacity 1 st layer kg	Capacity top layer kg	Lifting speed 1 st layer m/min	Lifting speed top layer m/min	Rope diameter* mm	Motor kW	Classification FEM/ISO	Useable rope length 1 st layer m	Useable rope length top layer m	Weight without rope kg
031140006	Mini	250	170	4.7	7.3	4	0.37	1Bm/M3	7	46.7	25
031140015**	Mini	250	170	3.7	5.7	4	0.55	1Bm/M3	7	46.7	25
031149065	BG 1	500	348	3.5	5.5	6	0.37	1Am/M4	8.4	58.5	65
031149077	BG 1	500	348	8.5	12.6	6	0.75	1Am/M4	8.4	58.5	65
031149254	BG 2	980	697	3.4	4.9	9	0.75	1Am/M4	11	77.5	114
031149259	BG 2	980	697	7.5	10.8	9	1.1	1Am/M4	11	77.5	120
031149302	BG 2	1250	814	5.9	9.2	9	1.1	1Bm/M3	8.7	64.1	125
031149438	BG 3	1600	1115	3.9	5.7	12	1.1	1Am/M4	12.1	87.8	204
031149441	BG 3	1600	1115	8.5	12.5	12	2.2	1Am/M4	12.1	87.8	210
031149533	BG 3.5	3200	2354	6.0	8.3	14	3	1Am/M4	11.4	64.5	224

*recommended rope: DIN 3069 FE-znk 1960 sZ-spa

**A.C. motor drive 230V

Dimensions model BETA SILVERLINE

Art.-No. Contactor	031140006	031140015*	031149065	031149077	031149254	031149259	031149302	031149438	031149441	031149533
A, mm	185	185	215	215	270	270	270	320	320	320
B, mm	170	170	300	300	400	400	400	510	510	510
Ø C, mm	12	12	13.5	13.5	18	18	18	22	22	22
F, mm	389	389	710	746	852	912	907	1014	1073	1101
G, mm	200	200	340	340	465	465	465	570	570	570
H, mm	241	241	333	319	490	487	490	614	599	684
K, mm	432	-	-	-	-	-	-	-	-	-
L, mm	180	180	200	200	250	250	250	300	300	300
Ø M, mm	64	64	108	108	175	175	138	218	218	242

*A.C. motor drive 230V

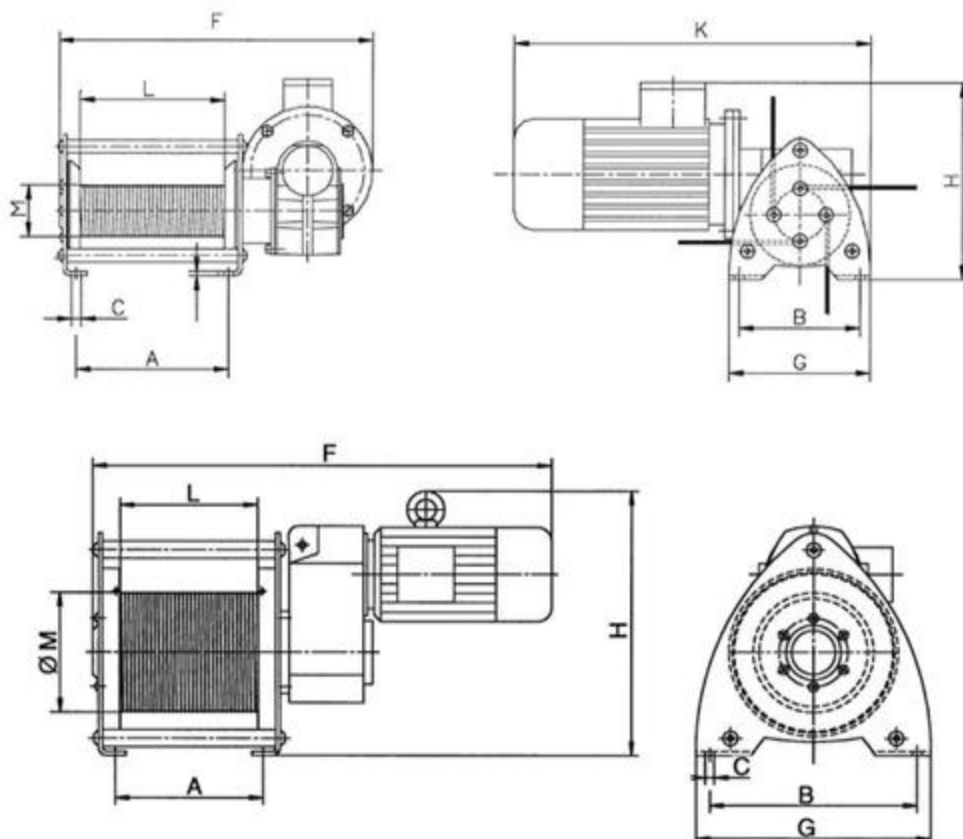

! Pfaff winches are not designed for passenger elevation applications and must not be used for this purpose.

DLHONLINE



Available in explosion proof version.



Application oriented winch solutions

Find out more about this product or get a quotation

In compliance with accident prevention regulations BGV C1, also available for application on stages and in studios.

Options

- Various drum designs e.g. extended for a larger rope capacity, special rope drums for operation with several ropes.
- Rope pressure rollers to prevent the unloaded rope from jumping off the drum.
- Adjustable gear limit switch for limiting the rope path in both directions.
- Slack rope switch for automatically stopping the winch when the rope tension eases or when the load is set down.
- Frequency inverter for infinitely variable speed control.
- External operation via cable/radio
- Other operating voltages
- Other motor protection
- Absolute or incremental encoder
- Pole-changing motors
- Special preservation

Electric winch model SW-E BETA PROLINE

Capacity 250 - 7500 kg

When it comes to individual solutions or highly specialized applications we recommend our winch model BETA PROLINE. Major fields of application are entertainment, explosion protected environments and everywhere where our standard winch models RPE and BETA SILVERLINE do not meet the demanding requirements.

Electric winches of the BETA PROLINE range are used for lifting, towing and positioning of loads under demanding conditions. All models are based on a modular system; a high degree of flexibility ensures tailor-made solutions owing to a large number of options.

The application of high-quality components and gear motors ensure safety and a long service life.

Features

- The electrically released spring pressure disc brake safely holds the load also in the event of a power failure.
- Powerful three-phase AC drives for multi-range voltage 380 - 420V, 50 Hz or 440 - 460V, 60 Hz. Motor type of enclosure IP55, duty factor 40% ED.
- Electronic overload protection from 1000kg lifting load as standard.
- The maintenance-free, oil lubricated gearbox has quiet running characteristics due to milled and ground gears with helical teeth.
- All parts with high-quality two component paint (RAL 5015, coat thickness approx. 120µm), rope drum zinc-plated in addition.
- Standard rope drum of grooved design, with large rope capacity.
- Variable rope lead-in due to two rope attachment points (left and right).
- Increased operating safety due to 42V contactor control.
- Complies with accident prevention regulations BGV D8.

BETA PROLINE winches are customized and made to order products that are only available on request.

For determining the required rope length, please take into account that at least 2 to 3 windings must remain on the drum!

DLHONLINE

Sheave block
for rope guidance,
equipped with ball bearings
model DSRB S

Find out more about this product or get a quotation

Technical data model DSRB S

Model	Art.-No.	Classification FEM/ISO	Pulling force	Pulling force	Rope diameter mm
			in kg at deflection 90°	in kg at deflection 180°	
DSRB S 90/4	033447103	2m/M5	700	500	4
DSRB S 145/5	033447104	4m/M6	1100	800	5
DSRB S 145/6	033447105	2m/M5	1100	800	6
DSRB S 185/8	033447107	2m/M5	2300	1630	8
DSRB S 185/9	033447108	1Am/M4	2300	1630	9
DSRB S 270/12	033447111	2m/M5	2500	1800	12
DSRB S 325/14	033447117	2m/M5	4500	3200	14
DSRB S 400/16	033447113	3m/M6	5000	3800	16
DSRB S 400/18	033447114	2m/M5	5000	3800	18
DSRB S 490/20	033447115	3m/M6	8000	6000	20



Dimensions model DSRB S

Model	DSRB S 90/4	DSRB S 145/5	DSRB S 145/6	DSRB S 185/8	DSRB S 185/9	DSRB S 270/12	DSRB S 325/14	DSRB S 400/16	DSRB S 400/18	DSRB S 490/20
Art.-No.	033447103	033447104	033447105	033447107	033447108	033447111	033447117	033447113	033447114	033447115
B, mm	85	125	125	138	138	191	260	302	302	313
C, mm	90	160	160	195	195	290	350	430	430	580
Ø D, mm	90	145	145	185	185	270	325	400	400	490
Ø D1, mm	20	25	25	30	30	40	50	50	50	65
Ø Dm, mm	80	125	125	160	162	246	297	368	364	450
E, mm	62	88	88	106	106	138	180	212	212	220
H, mm	134	224	224	273	273	407	490	612	612	694
K, mm	65	110	110	135	135	202	242	310	310	340
L, mm	120	200	200	245	245	360	440	530	530	650
Ø M/M1, mm	9/9	11.5/13	11.5/13	13.5/15	13.5/15	18/20	22/25	26/30	26/30	34/40
S, mm	4	6	6	8	8	10	12	15	15	16

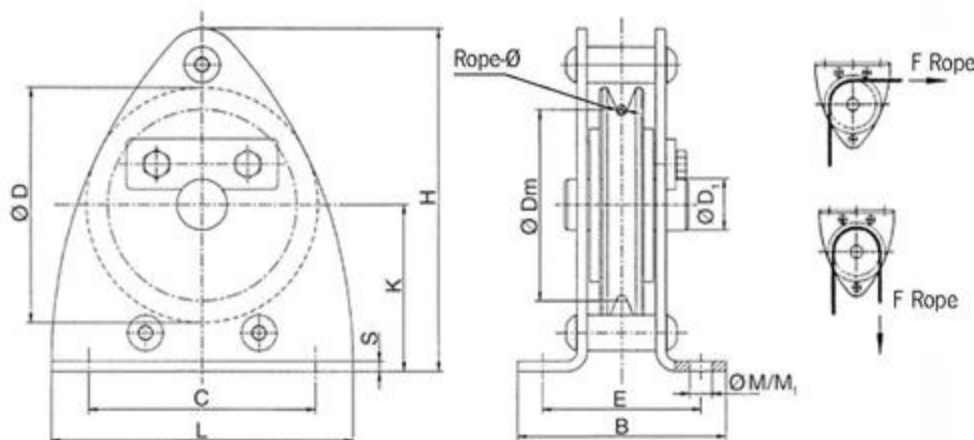

DLHONLINE



Endless winch for the transportation of goods- and personnel model YaleMtrac

With the new YaleMtrac, the rope is driven through the winch without the necessity of having to collect the rope on a reel etc. This enables unlimited lifting heights or traction lengths. Unlike a drum winch, the wire rope always enters the winch at the same place, thus eliminating undesirable hook movement across the drum and ensures rope speed and pulling force remain constant. Endless winches can be used for various applications, wherever loads have to be lifted or pulled, e.g. for the use on waggons, mobile scaffolds, or wind power stations.

Features

- The robust, precisely machined housing of die-cast aluminium ensures a low deadweight and outstanding rigidity. Standardised components feature easy access to all wearing parts.
- Drive sheave and pressure rollers made of specially hardened steel guarantee low wear of the components.
- Limit switch for lifting force as standard (only for winches for passenger elevation).
- The winch can be suspended from a central suspension point by means of a load pin. As an alternative, attachment points in the corners of the housing are available for flexible attachment of the winch with screws or pins.
- Classification:
1 Bm/M3 (1 Cm/M2 for 18 m/min) according to FEM
- All motors protected to IP 55 as standard, against ingress of dust and water jets.
- Standard operating voltage:
Euro-voltage 400V, 3-phase, 50 Hz alternatively 460V, 3-phase, 60 Hz.
- 24 V control voltage (except material transport control, stationary application – 42 V)
- Phase monitoring (except material transport control, stationary application) for an easy and safe connection to changing power supply.
- Hoist motor with thermal overload protection as standard for increased lifetime.
- Certified by an independent inspection institute (DGUV).
- Certified for passenger elevation applications in accordance with DIN EN 14492-1 by an independent inspection institute (DGUV).

Find out more about this product or get a quotation

Certified for passenger elevation applications in accordance with DIN EN 60204-32 by an independent inspection institute (DGUV).

Options

- Other operating voltages
- Radio remote control
- Double control for several winches
- Limit switch for upward and downward travel.
- Counters for operating hours and number of starts.
- Catching devices (overspeed or inclined position tripping, required for passenger elevation applications).
- Adaptor for fitting with shackle
- Ropes for endless winches and catching device.
- Overload protection (included in the scope of supply for passenger elevation winches).
- Storage reel for the unloaded rope.

DLHONLINE

Technical data model YaleMtrac Winches for material transport

Model	EAN-No. 4025092* for stationary application**	EAN-No. 4025092* for mobile application***	Capacity kg	Lifting speed m/min	Rope diameter mm	Motor kW	Weight for stationary application** kg	Weight for mobile application*** kg
YMT 5-9-M8	*668569	*668644	500	9	8.4	1.1	54	62
YMT 5-18-M8	*668576	*668651	500	18	8.4	2.0	54	62
YMT 6-9-M8	*668583	*668668	600	9	8.4	1.1	55	63
YMT 6-18-M8	*668590	*668675	600	18	8.4	2.0	55	63
YMT 8-9-M8	*668606	*668682	800	9	8.4	1.8	55	63
YMT 8-18-M8	*668613	*668699	800	18	8.4	3.6	56	64
YMTF 8-18-M8	-	-	800	18/9	8.4	2.0/3.6	58	66
YMT 10-9-M9	*668620	*668712	980	9	9.0	1.8	55	63
YMT 10-18-M9	*668637	*668705	980	18	9.0	3.6	56	64
YMTF 10-18-M9	-	-	980	18/9	9.0	2.0/3.6	58	66

**incl. control voltage 400V, 3-phase, 50 Hz, directly attached to the winch, pendant control with emergency-stop (length of control cable 3 m)
 ***incl. control cabinet with integrated CE-connector, pendant control with emergency-stop (length of control cable 3 m)

Contact control for material transport applications (stationary application)

- Control cabinet (260 x 124 x 95 mm)
- Protected to IP 55 (acc. to EN 60 529)
- Temperature range -20 °C up to +40 °C
- Increased operating safety through 42V control voltage
- Master control relay/emergency-stop contactor as standard for a high degree of safety
- Easily accessible strip terminal
- Cable entry point by cable sleeves
- Motor connected with control cable



Hoist motor & brake
 Special motor with classification 1 Bm/M3 (1 Cm/M2 for 18m/min) according to FEM/ISO 4301-1. Protected to IP55.



Flexible attachment points
 Central load pin suspension or alternatively screws or pins on four corners.

Control cabinet for material transport applications (mobile application)

- Control cabinet (300 x 400 x 150 mm)
- Protected to IP 55 (acc. to EN 60 529)
- Temperature range -20 °C up to +40 °C
- Increased operating safety through 24V control voltage
- Master control relay/emergency-stop contactor as standard for a high degree of safety
- Phase-sequence relay for monitoring the direction of rotation
- Control transformer according to EN 61558-2, input and output separately fused
- Warning buzzer for signalling an overload
- Easily accessible strip terminal
- Cable entry point by screwed cable glands
- Motor connected with connector plug
- Power supply connection with phase-changing switch.
- Connection for UP emergency limit switch provided.

Find out more about this product or get a quotation



Technical data model YaleMtrac Winches for passenger elevation according to EN 1808

Model	EAN-No. 4025092*	Capacity kg	Lifting speed m/min	Rope diameter mm	Motor kW	Weight without rope incl. control cabinet kg
YMT 5-9-P8	*668729	500	9	8.4	1.1	72
YMT 5-18-P8	*668736	500	18	8.4	2.0	72
YMT 6-9-P8	*668743	600	9	8.4	1.1	73
YMT 6-18-P8	*668750	600	18	8.4	2.0	73
YMT 8-9-P9	*668767	800	9	9.0	1.8	73
YMT 8-18-P9	*668774	800	18	9.0	3.6	74
YMTF 8-18-P9	*911313	800	18/9	9.0	2.0/3.6	76
YMT 10-9-P10	*668781	1000	9	10.2	1.8	73
YMT 10-18-P10	*668798	1000	18	10.2	3.6	74
YMTF 10-18-P10	*911320	1000	18/9	10.2	2.0/3.6	76

Incl. control cabinet with integrated CE-connector
 Incl. pendant control with emergency-stop (length of control cable 3 m)
 Option: Emergency-stop and UP/DOWN buttons on control cabinet for controlling the winch

all models	
A, mm	266
B, mm	300
Ø C, mm	16.5
Ø D, mm	10.5
E, mm	40
F, mm	57
G, mm	261
H, mm	34
I, mm	375
J, mm	261
K, mm	220
Ø L, mm	180
M, mm	301
N, mm	375
O, mm	599

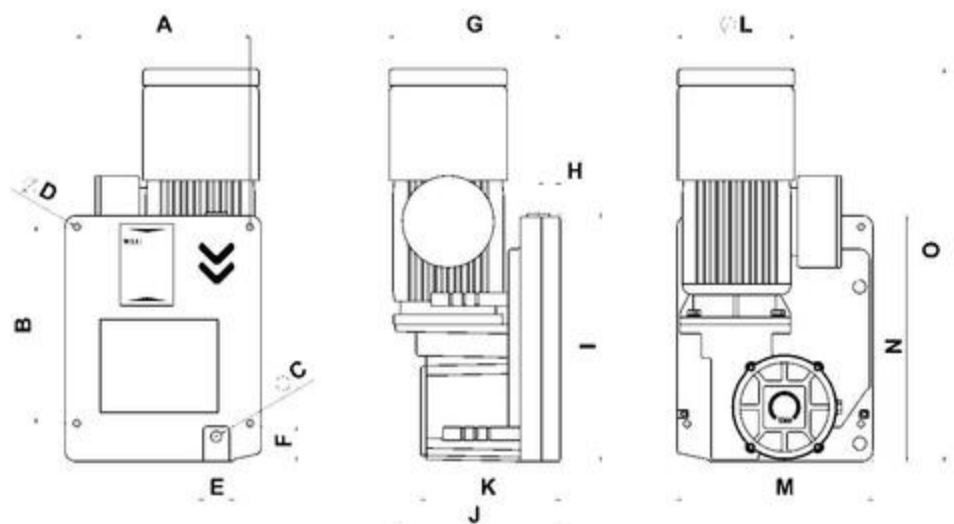

Find out more about this product or get a quotation

Options

- Control cabinet for synchronous control of two winches
- Supporting feet and arms for fixing the control cabinet



Control cabinet for passenger elevation applications

- Control cabinet (300 x 400 x 150 mm)
- Protected to IP55 (acc. to EN 60 529)
- Temperature range -20 °C up to +40 °C
- Increased operating safety through 24V control voltage
- Master control relay/emergency-stop contactor as standard for a high degree of safety.
- Phase-sequence relay for monitoring the direction of rotation.
- Control transformer according to EN 61558-2, input and output separately fused.
- Warning buzzer for signalling an overload
- Easily accessible strip terminal
- Cable entry point by screwed cable glands
- Motor connected with connector plug
- Power supply connection with phase-changing switch
- Connection for UP emergency limit switch provided

DLHONLINE

Safety for passenger elevation

In accordance with the requirements of DIN EN1808, each winch used for passenger elevation must feature a safety system on an independent safety rope. The product offering provides two different safety catching devices for two common applications.

Both types have been approved for passenger elevation and comply with standard DIN EN1808 "Safety requirements on suspended access equipment". In addition, the catching devices have been certified by an independent inspection institute (DGUV).



Safety hand wheel

In an emergency (power failure), upward movement with released brake is possible by means of the hand wheel included in the supply (standard delivery scope only for winches for passenger elevation application).



Safety lowering mechanism

In the event of a power failure, the electro-mechanical brake can be released manually in order to ensure safe and controlled lowering of the load. Safe lowering is guaranteed by the integrated centrifugal force brake.

Find out more about this product or get a quotation

Overspeed safety catching device (YOSL)

This overspeed catching device is automatically tripped when the lowering speed exceeds 30m/min (0.5m/s). The integrated clamping jaw mechanism of hardened steel stops the lowering movement of the system within a few centimetres.

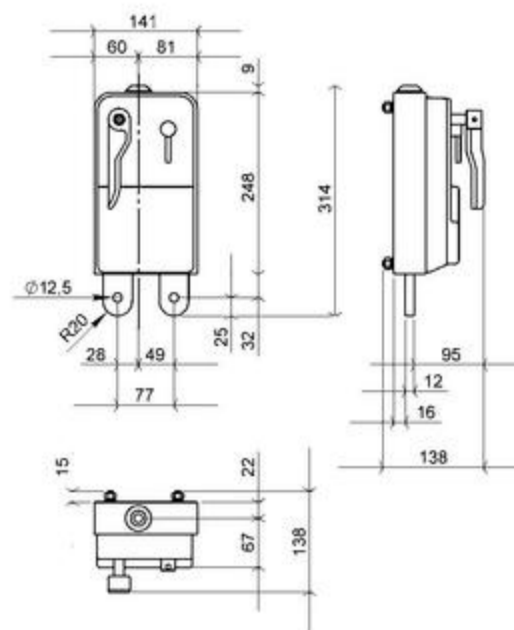

Model	EAN-No. 4025092*	Capacity kg	For rope diameter mm
YOSL6-8	*582803	500	8.4
YOSL6-8	*582803	600	8.4
YOSL8-9	*582742	800	9.0
YOSL10-10	*582766	1000	10.2

Inclined position safety catching device (YISL)

This inclined position catching device is automatically tripped when the angle of the rope or the platform exceeds 5°.

The integrated clamping jaw mechanism holds the rope and immediately stops the movement of the system.

- Robust sheet-steel enclosure
- Clamping mechanism of hardened steel
- Attachment with two screws (M12) or load pins (12mm)

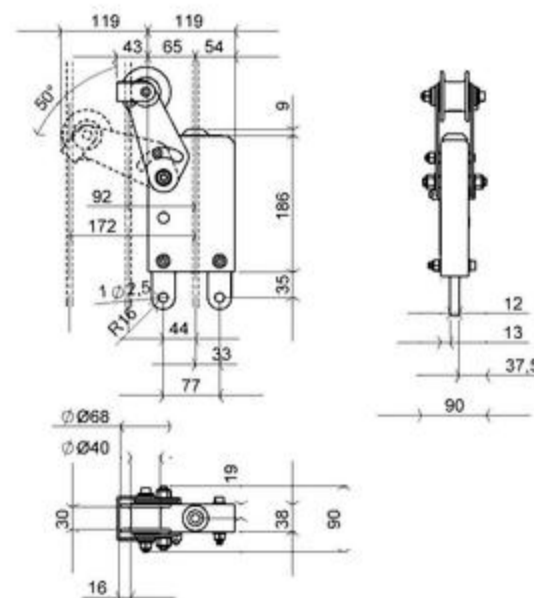

Model	EAN-No. 4025092*	Capacity kg	For rope diameter mm
YISL6-8	*582827	500	8.4
YISL6-8	*582827	600	8.4
YISL8-9	*582759	800	9.0
YISL10-10	*582797	1000	10.2

DLHONLINE



Monorail trolley hoist with extremely low headroom model YGK-E

Extremely low headroom and compact design allow maximum hook travel. This robust and maintenance friendly hoist is suitable for many industrial applications. Due to the flexible and easily adjustable trolley, the YGK-E is easy and fast to install. Properties like the quiet and smooth running gearbox and the optimised drive characteristics of the trolley extend the life expectancy.

Features

- Monorail trolley with extremely low headroom as standard.
- FEM/ISO classification 2m/M5. As required (with appropriate changes to lifting capacity resp. duty cycle) the model YGK-E can also be re-classified to 3m/M6.
- Control cabinet with contactors (42 V control voltage) for both trolley and hoist.
- The motor is located outside the rope drum permitting good cooling and serviceability.
- Hoist motor with thermal overload protection and limit switch, phase and motor monitoring.
- Low maintenance brake protected to IP 65
- Motor protected to IP 55 as standard (acc. to VDE 0530), insulation class F, against ingress of dust and water jets.
- Standard operating voltage: Euro-voltage 400V, 3-phase, 50 Hz; alternatively 460V, 3-phase, 60 Hz.
- Proven enclosed low wear rope guide made of glass reinforced polyamide ensures guiding and tensioning of the rope full 360° to avoid slack rope and subsequent damage to the rope.
- The rope can be exchanged and maintained quickly due to three screwed rope clamps and an asymmetrical wedge socket. The open design allows easy maintenance.
- Two-speeds for lifting and traction drive each. Ideal handling characteristics as two wheels are driven, one on each side of the frame. Trolley wheels are mounted on prelubricated, encapsulated ball bearings.
- Robust bottom block made of glass reinforced polyamide.
- Rotating and tiltable load hook trunnion style for easier load adjustment and positioning.

Contact us for information on this product on 0161 223 1990



Geared limit switches

The geared limit switch for the upper and lower hook position is conveniently located to allow easy access.



Adjustment to beam flange

Simple adjustment of the trolley to a wide range of beam flange widths by threaded spindle



Overload prevention device

prevents lifting excessive loads

Options

- Other operating voltages
- Two-speed push-button pendant for trolley and hoist control.
- Two-speed push-button pendant for crane travelling, trolley and hoist control.
- Radio remote control
- Control cabinet with contactors for crane control.
- Other beam flange widths.
- Festooned cable system

DLHONLINE



DLH online
DALE
Lifting and Handling
Specialists

Dale Lifting and Handling
2 Kelbrook Road
Manchester
England
M11 2QA

Main website www.dlhonline.co.uk
Contact us
Local: 0845 270 2919
International: +44 (0) 161 223 1990
Email: sales@dale-lifting.co.uk

