

DLH ONLINE

A GUIDE TO LIFTING BEAMS AND SPREADERS

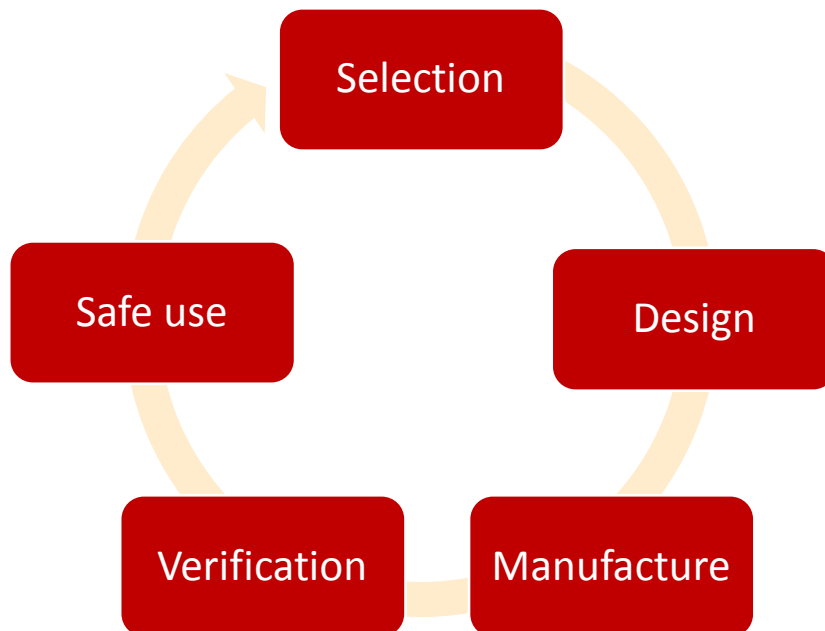

a comprehensive guide for
specifiers, buyers, and
responsible persons

Overview



This easy-to-read and comprehensive guide to lifting beams and spreaders contains information extracted from the [LEEA](#) guidance - The verification of spreader beams, lifting beams and lifting frames.

It covers all aspects of the selection, design, manufacture, verification, testing, repair, modification, storage, inspection and safe use of lifting beams and spreader beams.

The table of contents ([Next page](#)) lists the sections covered and contains links to each section. For ease of use, each section is linked back to the table of contents.

Table of contents

Sections	Title	Page No./link
1	Why use a lifting beam?	3
2	Lifting beam -v - Lifting spreader	4
3	Variations	5
4	Making sure the load is stable	6
5	Multi-purpose designs	9
6	Standards for lifting beams and spreaders	10
7	Documentation	11
8	Design standard	12
9	Technical file	12
10	Verification methods	14
11	Verification through calculation	15
12	Verification through test	17
13	Load testing with weights	18
14	Load testing by means of an applied force	19
15	Verification of lifting beam with moving parts	20
16	Verification of ancillary items	22
17	Attaching the lifting beam to the crane and load	23
18	Beam markings and identification	24
19	Markings	25
20	Considerations for headroom	26
21	Storage	27
22	Instructions for safe use and maintenance	28
23	In-service inspection of lifting beams	29
24	Verification of repairs and modifications	30
25	Our Services	32
	Contacting us	33

1. Why use a lifting beam?

Lifting beams, frames and spreaders are usually designed and built for a specific purpose. The range of designs and capacities is therefore only limited by practicality.

It is important to take care in selecting the right type of beam to be used and to plan the lift taking the following into account:

- Application requirements - to reduce headroom, provide multiple lifting points, to provide adjustable lifting centres, to handle out of balance loads, to remove or control inward or crushing forces, to allow for special load attachments.
- Calculations to be made will include the capacity, both of the overall beam and of the loading of the individual lifting points.
- Another important consideration is the centre of gravity of the load to be lifted, together with any accessories and or attachments used - slings, grabs, shackles, hooks, magnets, vacuum pads etc.

[\(Back to table of contents\)](#)

2.

Lifting beam - v - Lifting Spreader

Lifting beams, Lifting frames and Lifting spreaders are a means of providing two or more lifting points from the hook of the lifting machine or crane spaced so as to match the position of the lifting points on the load. The difference lies in the way the forces are transmitted.

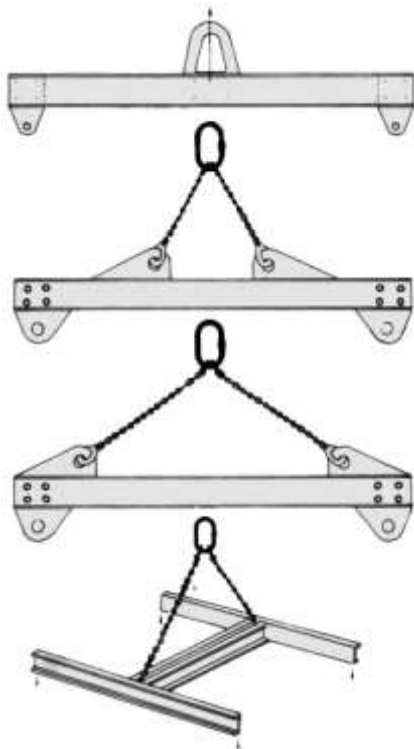

A lifting beam is loaded in bending. Typically a simple lifting beam will have a single lifting eye above the beam which engages with the lifting machine hook and lower lifting eyes at points on the underside of the beam to connect to the load.

A spreader, often called a spreader beam, is actually a strut loaded in compression. Typically a simple spreader will have a suspension sling which connects the lifting machine hook to the ends of the spreader which are then connected to the load. This arrangement enables the sling to lift, e.g. A cable reel from its axle whilst preventing the sling legs damaging the drum flanges.

The design of modern spreaders is usually much more sophisticated but the principle is the same. In practice a combination of beam and spreader is often used and whilst the terms are often used interchangeably, the equipment itself is not interchangeable. It must be loaded in the manner for which it was designed.

[\(Back to table of contents\)](#)

3. Variations

Another variation of the lifting beam is one designed to connect two overhead travelling cranes and provide one or more lifting points.

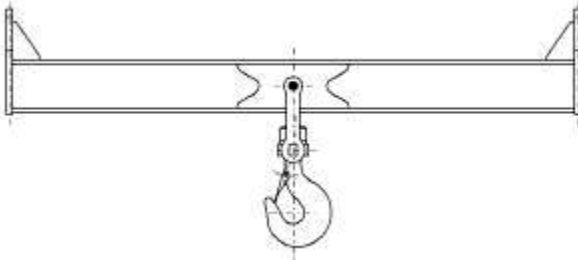

This facilitates tandem lifting. The total lifting capacity can be that of the two cranes less the self-weight of the beam and any allowance for uncertainty in the sharing of the load.

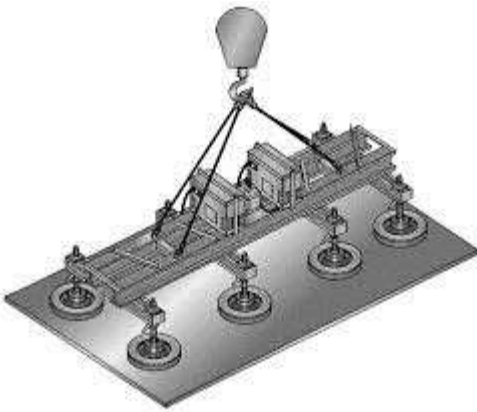

Most lifting beams and spreaders will be designed for specific applications e.g. A lifting beam for use with vacuum pads or lifting magnets to lift long flexible loads which needs support at regular intervals to prevent sagging.

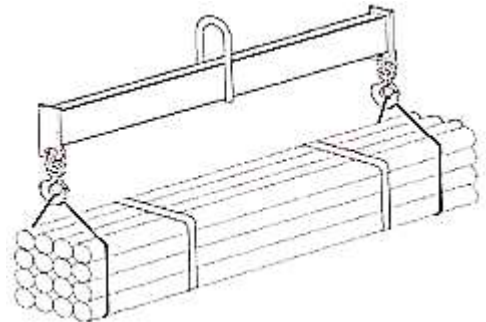

A spreader might be designed to lift a load such as a vehicle or boat, lifting it from the base but keeping the slings clear of easily damaged areas.

4. Making sure the load is stable



Lifting beams and spreaders are often used when there is limited headroom. Ideally it is best if the attachment points on the load are above its centre of gravity as that will ensure that the load will always hang in a stable position.

However if the lifting beam or spreader is connected to the load by slings which attach to the load below its centre of gravity, care is needed to ensure that the load will be stable when lifted.

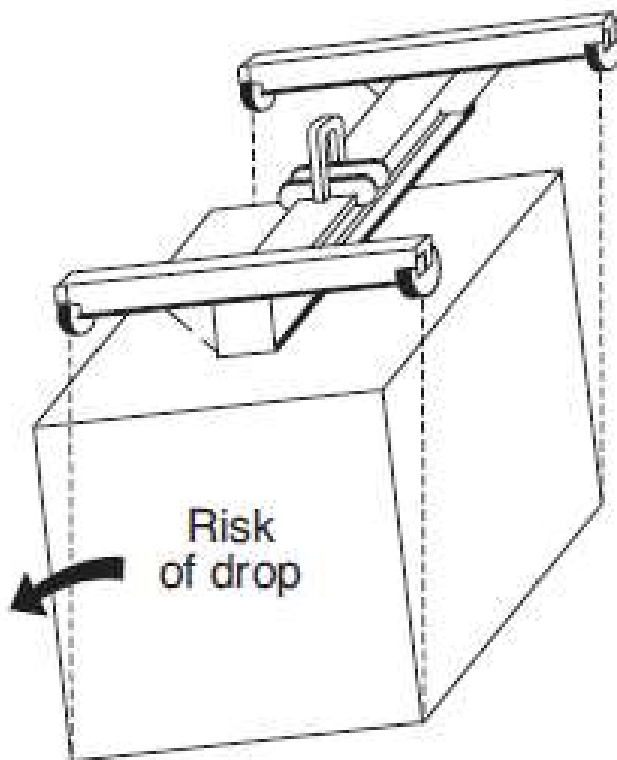

A typical application of this kind might be a container lifted from the base. The lifting beam is connected to the container base by four vertical single leg slings.

When viewed from the side, the lifting beam, container and slings form the four sides of a rectangle.

Without triangulation the four sides form a mechanism which can deform into the shape of a parallelogram. That is what happens if the load is unstable and starts to topple.

(Continued next page)

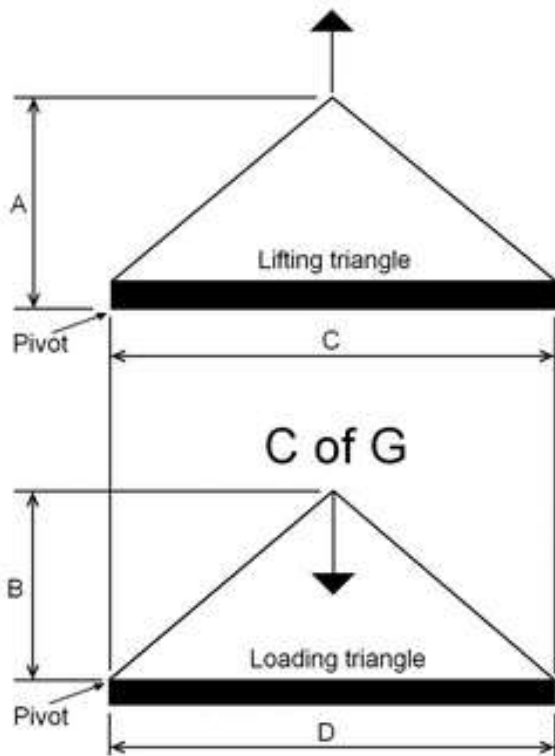

Looked at from the side, the figure left illustrates the situation.

The forces which prevent or cause toppling come from the vertical distance from the seat of the lifting machine hook to the sling attachment points on the lifting beam (A) and the distance of the centre of gravity above the attachment points on the skid (B).

The centre of gravity will always try to be as far from the hook as possible. If (A) is greater than (B) the arrangement will be stable. The larger the difference, the more stable the arrangement will

be. However if (B) is greater than (A), the arrangement will be unstable and will topple. The relationship between dimensions (C) and (D) also affect stability. If (C) is greater than (D) the arrangement will be less stable.

The issue of stability should be considered at the lift planning stage and not left to checking at the time of rigging.

The static friction at the pivot points can be sufficient to allow a well balanced load to be lifted vertically. However when a travel motion is started this can be sufficient to break the frictional grip and, once the load starts to topple, there is no going back.

(Continued next page)

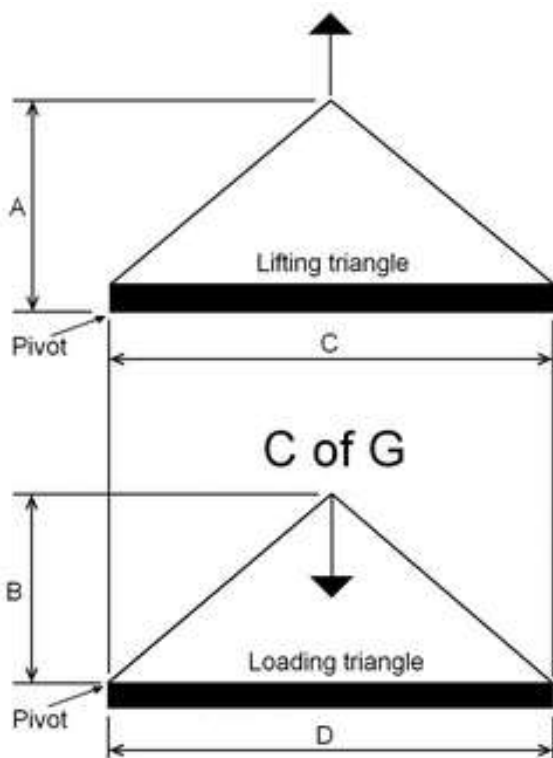

The example described is a four point lifting arrangement but the same problem can occur with other arrangements.

For example a load held by two slings in basket hitch, one at either end connected to a straight lifting beam. Viewed end on, the load is held securely with triangulation provided by the basket hitch.

However, viewed from the side, there is the rectangular mechanism supporting the load from below the centre of gravity with only the friction between the slings and the load to stabilise it.

Lifting beams often have a profiled plate eye to engage with the lifting machine hook. This keeps dimension (A) to a minimum but can cause stability problems for these types of applications. The obvious way to ensure stability is for dimension (A) to be significantly greater than (B) and this is where a spreader, suspended by a sling, often has the advantage over a lifting beam.

Alternatively the combination design previously referred to can be used. In this the beam is suspended from a sling connected part way along the beam rather than at the ends. It increases the (A) dimension and the forces in the beam are a combination of bending and compression.

[\(Back to table of contents\)](#)

5. Multi-purpose designs

Lifting beams and spreaders can also be designed for multi-purpose applications.

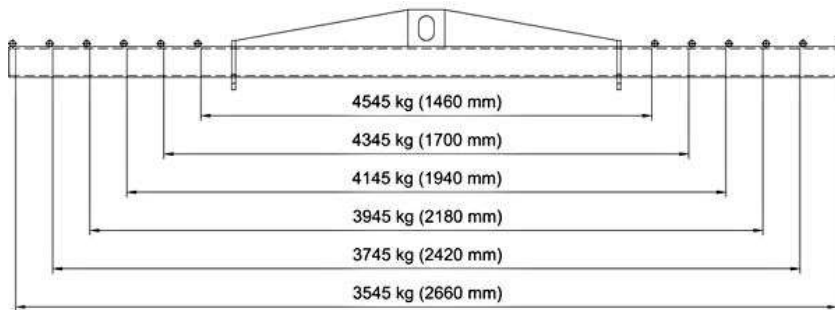

There are two basic approaches to this. Lifting beams can have adjustable lifting points which can be moved along the beam to suit the particular load.

Spreaders can be made in modules which are assembled into the configuration required. Lifting beams and spreaders of these types make it cost effective for one off or limited applications.

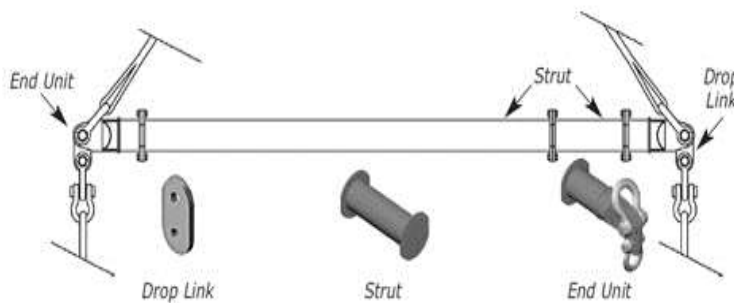

Lifting beams can also be designed for applications where the load is to be

intentionally tilted or where the position of the top suspension eye needs to be adjusted to match the centre of gravity of the load.

Designs which incorporate adjustable lifting points or tilting facilities should take account of the possible operator errors in not adjusting or tilting accurately.

[\(Back to table of contents\)](#)

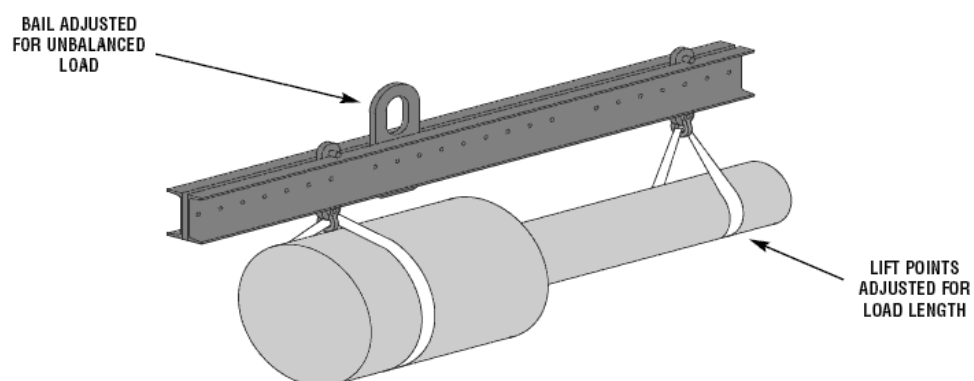

6. Standards for lifting beams and spreaders

There is a harmonised European Standard, EN 13155, which specifies the requirements for lifting beams and spreaders. It deals with all these variations as well as specifying the fundamental requirements. Buyers are advised to specify this standard.

Lifting beams are classified as lifting accessories and fall within the scope of the Supply of Machinery (Safety) Regulations 2008. The current harmonized standard BSEN13155:2003+A2:2009m: Cranes - Safety - Non Fixed Load lifting attachments. This standard should be adopted as best practice to ensure conformity to the minimum requirements of the Machinery Directive.

Prior to this standard and the Directive there was no specific standard for the manufacture of Lifting Beams. Manufacturers would often, therefore, work to the requirements of other standards for weldable structural steels, such as BS 449 and BS 2573.

For the verification of lifting beams, the International Labour Organisations (ILO) code of practice for Safety and Health in Ports included a sliding scale of proof forces linked to the capacity of the lifting beam.

However these values were not adopted in EN 13155 and, for higher capacities, are in conflict with the minimum requirements of the Machinery Directive.

Once in service lifting beams fall under the Provision of Use of Work Equipment Regulations and the Lifting Operations and Lifting Equipment Regulations (LOLER).

[\(Back to table of contents\)](#)

7. Documentation

Lifting beams are classified as lifting accessories and fall within the scope of the Supply of Machinery (Safety) Regulations 2008.

It is therefore required that they are supplied with an EC Declaration of Conformity and instructions for use and maintenance (refer to 3.3).

The EC Declaration must contain the following information:

- The name and address of the manufacturer.
- The name and address of the manufacturers authorised representative.
- The name and address of the person responsible for compiling the technical file.
- Description of the equipment, Type, serial number, WLL, self-weight (including ancillary equipment, details of the ancillary equipment supplied attached or to be used with the equipment.
- Standards and specifications used.
- Place and date of the declaration.
- A declaration claiming conformance with the essential health and safety requirements as defined in the directive 2006/42/EC
- Name, position and signature of the person making the declaration.

[\(Back to table of contents\)](#)

8. Design

When designing Lifting Beams and spreaders it is important that the minimum requirements of the Supply of Machinery (Safety) Regulations are met in full. This part of the guidance will address the criteria that must be considered, though it is also recommended that BS EN 13155 is followed.

[\(Back to table of contents\)](#)

9. Technical File

The technical file is very important and must contain all the information that went into the manufacture of the lifting beam.

Should a lifting beam fail in service, then it is this technical file that will be scrutinised. If it cannot be proven that other factors, such as misuse, were not to blame for the failure, then it is vital that information within the technical file shows that the manufacturer has done everything reasonably practicable to ensure the safety of the equipment.

The technical file does not have to be a physical entity, but it must be able to be assembled from various sources should the need arise.

See next page for information required.

Information required for a technical file

Typical information that should form a technical file for lifting beam is as follows:

- A list of the EHSRs which apply to the lifting beam
- A description of the methods used to eliminate hazards or reduce risks
- A list of standards to which the equipment has been made. This should include standards used for accessories that are supplied fitted to the beam, such as shackles, chains, wire ropes, etc.
- Information from the user. This should include such detail as to the geometry and mass of the load, including the centre of gravity. Details of the lifting appliance should be included, such as the size of the hook, the SWL and the work envelope between the appliance and the load is also important.
- Design information. Calculations, detailed drawings and fabrication / welding procedures.
- Material traceability. Details of all materials and assemblies should be retained in the technical file. This could be a mill certificate for steelwork or an EC Declaration of Conformity for a sling.
- Test reports - these could be the reports of a load test or a non-destructive test done on the welds.
- Instructions for use

On completion of the technical file an EC Declaration of Conformity can be drawn up for the lifting beam(s) which should be added to the file.

[\(Back to table of contents\)](#)

10. Verification methods

With regard to strength, there are two main criteria to verify:

1. At the proof force, the maximum stress must be within the yield stress of the material being used.
2. At the minimum failure force, the load must not be released.

It is acceptable to verify these criteria using either of, or a combination of, two techniques, calculation or load test. Sections 10 and 11 address each method.

In some cases the beam will be designed such that it can rotate or tilt. It may also have moving parts that can traverse along the beam.

These items require additional design and verification methods to be adopted. Section 15 addresses lifting beams with moving parts.

[\(Back to table of contents\)](#)

11. Verification through Calculation

The person producing the calculations must have sufficient theoretical knowledge and experience of lifting beams to ensure that the design is safe and fit for purpose. It is also recommended that these calculations are suitably checked.

However, it should be noted that this does not necessarily have to be done by another competent person, as often or not computer simulation is used in the verification of lifting beams.

When using computer simulation it is advisable that the results are checked by simple hand calculation. These hand calculations should be able to ascertain if the stress is about right or if the beam is deflecting the correct way.

The calculations used and or computer simulation must accurately simulate the in-service forces that will be induced by the load. Consideration must be given to the nature of the load.

For example, is it flexible or rigid? If the load is flexible, then the beam may require sufficient rigidity to prevent the load being damaged.

Conversely a rigid load may require some flexibility in the lifting beam to ensure uniformity of loading.

Examples of the type of calculation that must be considered are as follows:

- - Critical buckling loads.

Note: that with some spreader beams the compression load will be applied eccentrically due to the shackle point being offset from the beam axis by the pad eye. *(Continued next page)*

Solving equations for eccentric buckling can be quite time consuming as the critical buckling load cannot be solved explicitly and a root-finding technique using numerical methods has to be used. To save time designers often use widely accepted computational methods where successive substitution with assured convergence can be applied. MathCAD and FEA are examples of such software.

- - Bending, shear and torsional stresses.
- - Lateral buckling of the flange or web of a beam. Refer to BS EN 1993-1-1 clauses 5.5.2, 5.5.4 and 5.6).
- - Shear and bearing stresses for pad eyes.
- - Weld or bolt stress calculations (note a minimum of grade 8.8 bolts should be used).
- - Brittle fracture. Refer to table A.3

The limiting factors imposed by EN 13155 are that at two times the WLL the maximum stress must be within the yield stress of the material being used. At three times the WLL a nonlinear analysis of the structure must be done to ensure that critical parts of the structure will not fail such that the load is released, although permanent deformation is allowed.

Note: the design factors only take into consideration the dynamic effects of lifting and do not include wind loads. Depending on the environment where the lifting beam is to be operated the wind pressure load on the item being lifted and the structure itself may also need to be included in the analysis.

The position of the lifting points on the load will affect stability if they are at or below the Centre of Gravity (COG).

It should be noted that the design calculations, being based on idealistic theoretical assumptions, cannot account for everything. It is therefore recommended that the beam is thoroughly examined by a competent person before putting into service. The extent of this examination would be down to the competent person and may include NDT of critical welds.

[\(Back to table of contents\)](#)

12. Verification through test

A load test should always be planned on the assumption that the item under test might fail and adequate precautions should be in place to prevent injury to any persons and damage to anything other than the item under test.

If the minimum failure force is not verified by calculation, then, when using this method alone, at least one lifting beam will have to be destroyed.

An adequate test specification must be drawn up against the design criteria and acceptance criteria such as maximum permissible deflections or deformations for worst case loading conditions must be included in the specification.

For modular or adjustable lifting beams the worst case configuration(s) must be used for the test.

To meet the design criteria the test must accurately simulate the in-service loading conditions for which the beam has been designed, including a tolerance on orientation in use.

There are two common types of load testing that can be deployed by the tester to achieve this and they are described in section 13 and section 14:

[\(Back to table of contents\)](#)

13. Load testing with weights

- Test weights must be pre-weighed or used with a load cell in the line.
- The lifting appliance must be of adequate strength with sufficient head room.
- For higher capacity beams, containers may be required to house the weights and the self- weight of these containers must be considered.
- For loads that can flex, the test weights must be applied such that they can accurately simulate this affect.

To achieve this it may be required that a jig or mock-up of the load to be lifted is fabricated.

This may even require a controlled lift of the product to be lifted. However, testing by means of applied force may prove more accurate and cost effective in this instance.

- For loads that are rigid, the test weights must act as a single rigid load.

[\(Back to table of contents\)](#)

14. Load testing by means of an applied force

- The force can be applied by means of hydraulic or pneumatic actuators or by mechanical means such as wire rope pulling machines.
- The test rig(s) must have a calibrated load sensor or a calibrated load cell must be used in the load path. This equipment must be calibrated to BS EN 7500-1 and have an accuracy of no less than $\pm 2\%$
- By fixing the beam at the point where the lifting appliance hook would fit it is possible to use multiple applied force devices, with variable loads and amplitudes to accurately simulate a flexible load.
- Using this method it is possible to undertake separate tests for various elements of the lifting beam.

To ascertain whether or not the acceptance criteria has been met, the tester will need to use measuring equipment.

This measuring equipment will depend on the acceptance criteria, but it must be calibrated, and may include dial test indicators, strain gauges, etc.

Equipment used for measuring deflections must have a resolution such as to allow the measurement to within $\pm 5\%$ of the permitted deflection of the structure under test.

Following the proof force test the beam must be thoroughly examined. This examination may include an NDT of the critical welds.

Other details of the thorough examination can be found in section 24. of this guidance.

[\(Back to table of contents\)](#)

15. Verification of lifting beams with moving parts

If the lifting beam is designed to tilt then the manufacturer is responsible for specifying the maximum permissible tilt from the horizontal. The beam can be verified through calculation or test, but whichever method is used then it is important that all the criteria specified in section 13 and section 14 are addressed with the beam at an additional 6 degrees to the maximum intended tilt angle.

Some lifting beams will facilitate adjustment under load, manipulation or orientation of the load or other complications. In this case the test should be repeated at several positions throughout the range of movement. These positions should be selected to simulate the worst operational conditions and take account of the tilting tolerance required.

If the free movement of the tilting or rotating mechanism presents a hazard then it is important that the mechanism is equipped with a device to stop movement and to immobilise the load in its intended position.

In addition to the above some lifting beams will also have movable parts; such as pad eyes that can be adjusted along the length of the beam. It is important that any movable part is effectively held in place when under load. When the spacing between these moving parts is controlled by a power source, protection devices must be incorporated to prevent crushing and shearing hazards as specified in BS EN 349:1993+A1:2008.

The devices described above used to hold the movable component of the lifting beam in place under load, must be effective up to 6 degrees from the maximum intended tilting angle permitted for the lifting beam. If the devices work using friction then the frictional force should be at least twice the force due (*cont'd*)

to the self-weight of the parts and the working load limit for the maximum intended tilting angle plus 6 degrees.

1. As with the main structural calculations the verification of the restraining device can be done by calculation or by test. Each method is detailed as follows:

1. Calculation - The calculations should address all the criteria as outlined in section 13 However, if the beam can tilt then the analysis should be undertaken with the beam at plus 6 degrees from the maximum intended tilting angle. If the devices operate on a friction basis, the calculations shall demonstrate that at least two times the force due to the self-weight of the parts and the working load limit for the maximum intended tilting angle plus 6 degrees.

2. Test - The criteria set out in section 14 should be followed in addition to the following procedure.

With the moving part locked in position by means of its locking mechanism a force equal to two times WLL should be applied for a minimum of 1 minute at an angle of 6 degrees in excess of that specified by the manufacturer. The test should be carried out in both directions about the horizontal axis for each available locking position. If the moving part does not have a predetermined position but locks by friction, the test must be carried out at the two extremes of travel and at one intermediate part.

After the force has been removed then the moving part and the locking mechanism must be thoroughly examined by a competent person. To be considered acceptable, the part and the locking mechanism must sustain the load without slippage, deformation or failure. After release of the load there must not be any visible defects and the device must still operate freely.

[\(Back to table of contents\)](#)

16. Verification of ancillary items

Most lifting beams will be fitted with supplementary lifting accessories that are used to connect the lifting beam to the load and/or the lifting appliance.

Examples of such accessories are typically, slings, swivel hooks, fabricated plate hooks, grabs, clamps, magnets and vacuum lifters.

For ancillary equipment that has been bought in, information such as the EC Declaration of Conformity, manufacturer's certificate and instructions for use and maintenance must be included in the technical file for the beam assembly.

The instructions for use must be supplied with the beam assembly or incorporated in the beam assembly's instructions for use and maintenance.

Other items should be verified in accordance with an appropriate harmonised standard. Common standards to consider would be BS EN 13155, BS EN 818 and BS EN 13414.

[\(Back to table of contents\)](#)

17. Attaching the lifting beam to the crane and load

Connections to the crane or the load should be capable of being locked before lifting so as to prevent any accidental uncoupling. For example a shackle with a bolt, nut and cotter pin should be used.

If the lifting beam has suspended parts means shall be provided to adequately protect them from damage during coupling or uncoupling the lifting beam to or from the crane.

In the case where lifting beams have moving parts that can be traversed along the beam then there should be a means at each end of the beam to prevent them from falling off.

These moving parts must also have a device that will lock them in position when under load. If the means of locking the load attachment points is operated manually, then the state of locking must be visible to the operator.

[\(Back to table of contents\)](#)

18. Beam markings and Identification

The self-weight of the lifting beam or spreader is usually a significant part of the total weight on the lifting machine so should always be included in the calculation.

It is normal practice to mark the lifting beam or spreader with its self-weight. In the case of permanent assemblies such as a lifting beam with magnets, that will be the weight of the complete assembly.

The beam or spreader should have its own unique identification marks. Most lifting beams and spreaders have ancillary items such as slings and shackles which are detachable although normally kept as an assembly.

In such cases it is normal practice to mark each item with an ID mark linked to that of the assembly.

The certification for the lifting beam or spreader should cover the complete assembly, listing the main ID and those linked to it.

Multipurpose items may utilise general purpose lifting accessories selected by the rigger for the particular application. In that case each accessory should have its own unique ID and certification.

[\(Back to table of contents\)](#)

19. Markings

The lifting beam must be marked with the following information:

- The name and address of the manufacturer
- The CE mark
- The serial number
- Year of construction
- Total mass of the assembly
- Maximum working load in tonnes or kilograms

Note 1:

Where the maximum working load depends on the configuration of the lifting beam, each operating position must be provided with a load plate indicating, preferably in diagrammatic form or by means of tables, the working load for each configuration

Note 2:

Where the orientation of the beam is not obvious, this should also be indicated. A 'this way up' arrow may suffice.

Note 3:

Occasionally lifting beams are fitted with fork lift truck pockets. These pockets are either intended to allow a fork lift truck to lift the load with the lifting beam or to allow the beam to be moved from location to location only.

Whatever the intention, it is important that they are marked appropriately.

[\(Back to table of contents\)](#)

20. Considerations for headroom

If the lifting beam or spreader is for use with a double girder crane, remember that the upper limit switch is usually set so that the bottom block will rise up between the girders.



This will allow the lifting beam to foul the girders before the limit switch operates. Adjustment of the limit switch or a secondary operational limit is necessary. Relying on the operator is not good practice.

As with most equipment, lifting beams and spreaders have some limitations. Nevertheless they have many advantages and provide a method of handling loads which cannot easily be handled by other means. [\(Back to table of contents\)](#)

21. Storage.

It is important that when the lifting beam is not required it can be stored such that it is stable and protected from damage. To be regarded as stable it must not tip over when tilted to an angle of 10 degrees in any direction.

This can be achieved by adding feet to the design or by the provision of additional equipment such as a stand for example.



If the equipment is fitted with ancillary equipment then the storage should also incorporate suitable design features to provide effective protection.

Alternatively these items should be removed and stored separately. In the latter case the identity of the equipment must be maintained.

[\(Back to table of contents\)](#)

22. Instructions for use and maintenance.

Instructions for use and maintenance must be supplied with the beam. The Lifting Equipment Engineers Association has produced numerous safety information leaflets that can be used as a guide to the production of such a document, most notably reference to [SI 8.2](#) Lifting Beams and Spreaders should be made.

Instructions for safe use and storage

[Read safe use instructions](#)

For modular lifting beams details of the range of configurations and associated safe working loads should also be included. This can be done by means of supplying detailed assembly drawings.

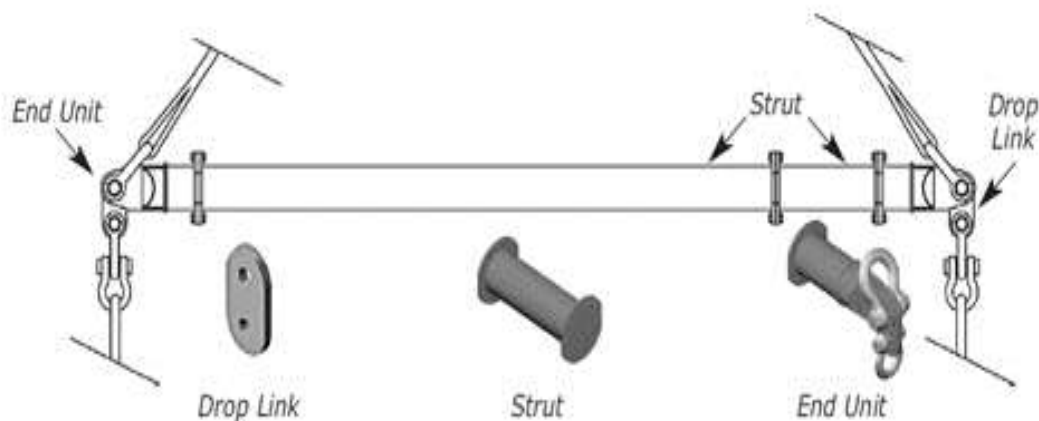

In addition to the above if it is not obvious as to the orientation of the beam, this information should also be provided and again schematics are the simplest method of doing this. [\(Back to table of contents\)](#)

23. In-service inspection of lifting beams

Under LOLER lifting beams are considered as lifting accessories and must be examined at least every 6 months, in accordance with an examination scheme (refer to LEEA 032 for guidance) or after exceptional circumstances.

The examinations should include the following:

- Checked for clear identification number.
- Checked for clear marking of SWL
- Checked main body of beam is free from distortion, corrosion, cracks, gouges, or wear.
- Checked all welded connections are free from cracking or corrosion.
- Checked that any bolted connections are free from corrosion and cracking and that all are secure using the correct bolts.
- Checked that any shackles fitted are free from distortion, nicks, gouges or wear.
- Checked that all shackle pins are captivated preferably with a nut and pin arrangement. Note: this list is not exhaustive, different configurations may require additional checks.

[\(Back to table of contents\)](#)

24. Verification of repaired and modification lifting beams

Lifting beams will inevitably get knocked about or even misused in service resulting in damage and the need for repair.

Whenever a Lifting beam is damaged requiring repair it is advised that the cause of the damage be investigated. It may be that the equipment is no longer adequate for the task.

Repair and verification due to in-service wear and tear

If a beam is to be repaired it is advisable that the original design specification is consulted.

Where this is not feasible then the repairer will have to take responsibility to ensure that the correct materials and components are used.

To that end the repairer must have adequate information about the application the lifting beam is used for.

A record of the repairs and details of the components used should be recorded on a job card and retained with the maintenance log of the equipment.

Following the repair the equipment should be thoroughly examined by a competent person.

In the case of a significant repair the beam may need to be NDT and or load tested.

Modification and verification

There are a variety of reasons why a lifting beam will be modified during its life.

It may be that the product it lifts has been altered requiring different distances between lift points or an increase in weight for example.

Whatever the reason it is important that the original design specification, test data, and technical file is referred to.

In the absence of this information then the person responsible for the modification will have to make assumptions as to certain aspects of the design in order to minimise the risk.

For example they may assume the lowest grade of steel for calculation purposes.

The modification would then have to be treated as making new equipment from second hand components and it is therefore recommended that sections 8 - 19 of this guidance is followed.

An EC Declaration of Conformity will then have to be drawn up.

[\(Back to table of contents\)](#)

25. Our services

Whether it's a Jet Fighter, Luxury Yacht, Printing Press, Museum Exhibit or Rubbish Skip - You will want to do it safely!

With an in-house design and manufacturing team and currently over 100 years of combined knowledge in the supply of innovative lifting solutions, we are your one-stop source for all lifting applications.

Our ISO 9001 service and membership of the Lifting Equipment Engineers Association makes us your number one choice in helping you make that lift in safety.

Our lifting beams are used to lift *1000's of tonnes* around the world by Aeronautical, Construction, Marine, Manufacturing and Logistics companies.



As members of the Lifting Equipment Engineers Association, we fully comply with LEEA Guidance - The Verification of Spreader Beams, Lifting Beams and Lifting Frames - in the design, manufacture and testing of our lifting beams and spreaders.

We can also provide proof load testing to client's new equipment and following modification or repair.

Special Note:

For proof load tests of new equipment, where we have not been contracted to provide design calculations, we will provide a report of proof load test for inclusion in the responsible person's technical file.

This document will provide a description of the item, identification markings, manufacturers' name, proof loads applied and test results, which will include deflections.

The integrity of design, manufacture and intended use will remain with the responsible person. Who must issue the declaration of conformity, affix the SWL, CE marking and instructions for safe use.

[\(Back to table of contents\)](#)

Contacting us



Click on the button (left) for more information about our bespoke lifting beams and spreader beams design and manufacturing service.

For more advice or to purchase the right equipment for your application you can contact our lifting beam design team:

DLH ONLINE

DALE

Lifting and Handling
2 Kelbrook Road
Manchester
M11 2QA

UK. 0845 270 2919

Intl. 00 44 161 230 1990

fax. 0161 223 6767

email sales@dale-lifting.co.uk

Website www.dlhonline.co.uk

VAT No. 145 5891 42

[\(Back to table of contents\)](#)